

REV	DATE	REVISION DETAILS	APPD
更改号	日期	更改内容	审核并批准
A	Apr.02.2020	Drawing Update	

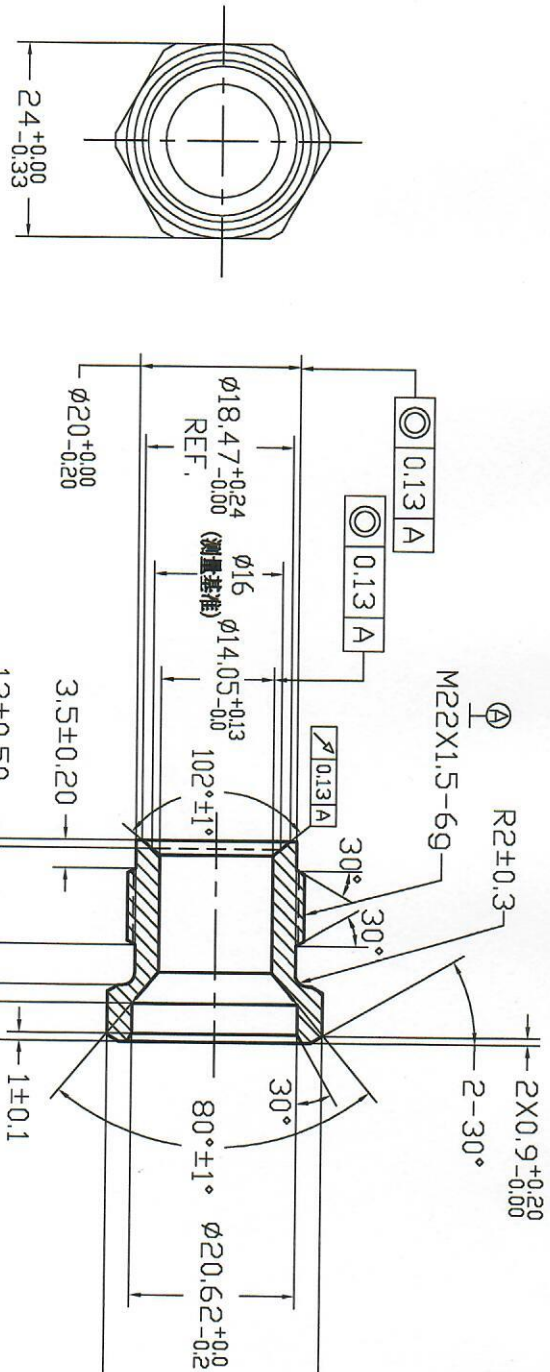

▽ 表示关键尺寸，必须达到

技术要求:

- 1、热处理硬度32-39HRC; 性能等级10.9级 (按螺纹紧固件分类标准) 抗拉强度 $\geq 1000\text{MPa}$; 屈服强度 $\geq 900\text{MPa}$
 - 2、零件表面涂防锈油
- Surface treatment: AFTER HEAT TREATMENT AND OIL DIPPED, HARDNESS 32-39HRC; PROPERTY CLASS OF 10.9 (AS PER THE STANDARD CLASSIFICATION FOR THREADED FASTENERS) WITH A TENSILE STRENGTH OF 1000N/mm².

UNLESS SPECIFIED
 ALL DIMENSIONS IN mm,
 MACHINED SURFACES Ra=3.2um,
 ANGLE TOLERANCES $\pm 1^\circ$,
 Other tolerance except angles,
 In accordance with
 GB/T1804-2000 (ISO2768-1)-m
 and GB/T1184-1996 (ISO2768-2)-m

其它事项,
 图示尺寸单位为mm,
 未注机械加工表面粗糙度 Ra=3.2um,
 未注角度公差 $\pm 1^\circ$,
 其它未注公差 (除角度外) 均按:
 GB/T1804-2000 (ISO2768-1)-m
 和 GB/T1184-1996 (ISO2768-2)-m

MATERIAL Chinese steel 42CrMo

FINISH Remove all sharp edges,burrs,slivers,rust and swarf, oil dipped or blackening,break all edges 0.127-0.254mm, oil dipped
 去除所有毛刺, 铁屑, 锈迹等残留物, 表面被防锈油或发黑处理, 破边倒钝0.127-0.254mm

Details of the dimple
 on 2 opposite flats
 (在六角面的二个正相对的
 面上各做一个标记)

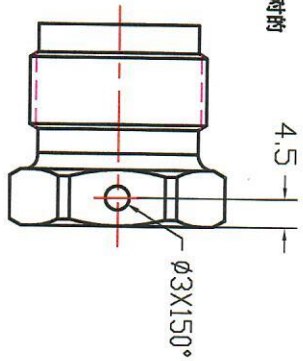

Zhejiang Gaocheng Autoparts Co.,Ltd

PART No
 零件名
22055-M22

SCALE: 批准
 NTS DATE: 日期
 APPD: 批准
 DRN: Sun Jianguan
 制图 20.04.02
 CHK: Li Junbiao
 审核 20.04.02