

REV 更改号	DATE 日期	REVISION DETAILS 更改内容	APPD 审核并批准
A	Jun.15,2019	Drawing Update	
B	25th Nov.,2022	change 22.75 +0.15/-0.15 改为22.60 +0.4/-0.4 change Dia. 25.10 - 25.35 to 25.4 +0.2/-0.2	<i>EL</i>

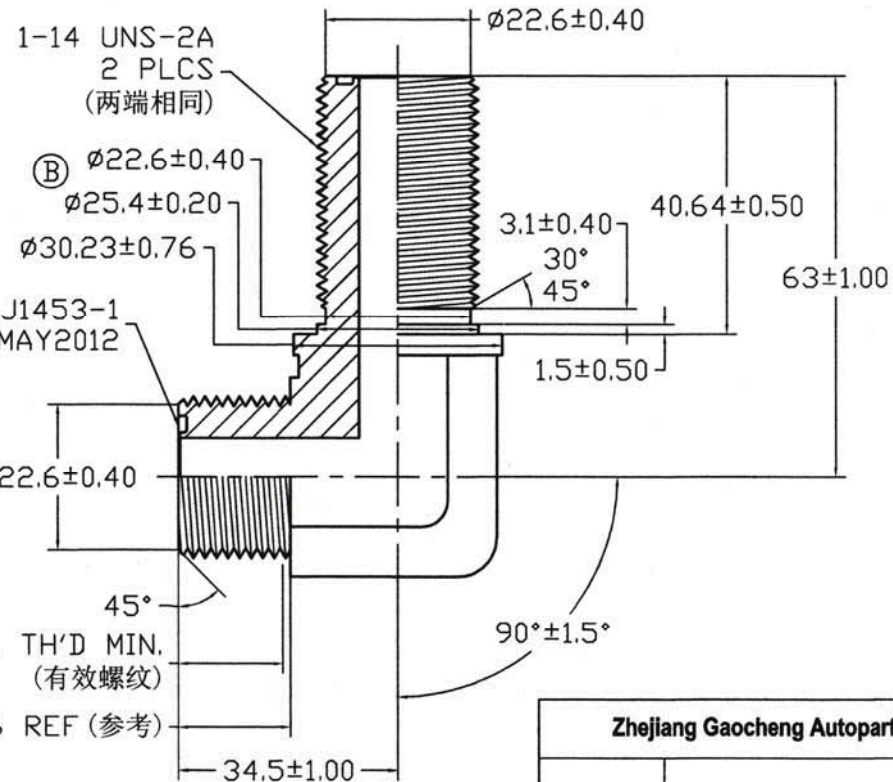
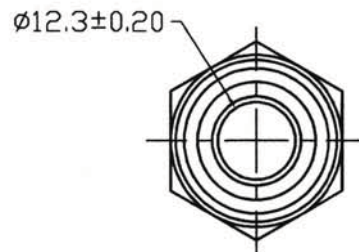
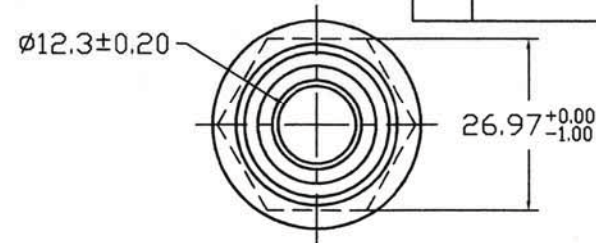

UNLESS SPECIFIED  
ALL DIMENSIONS IN mm,  
MACHINED SURFACES  $Ra=3.2\mu m$ ,  
ANGLE TOLERANCES  $\pm 1^\circ$ ,  
Other tolerance except angles,  
in accordance with  
GB/T1804-2000(ISO2768-1)-m  
and GB/T1184-1996(ISO2768-2)-m

其它事项,  
图示尺寸单位为mm,  
未注机加工表面粗糙度  $Ra=3.2\mu m$ ,  
未注角度公差  $\pm 1^\circ$ ,  
其它未注公差 (除角度外) 均按:  
GB/T1804-2000(ISO2768-1)-m 和  
GB/T1184-1996(ISO2768-2)-m

SEE SAE J1453-1  
REVISED MAY2012

14 FULL TH'D MIN.  
(有效螺纹)  
17.6 REF (参考)

Zhejiang Gaocheng Autoparts Co.,Ltd	
PART No 零件名	2701-10FS-10FS
SCALE:	APPD: 批准 <i>EL</i>
NTS	DATE: 日期 <i>EL</i>
	DRN: Pan 制图 2019.06.15
	CHK: Pan 审核 2019.06.15

MATERIAL	Chinese steel 45
FINISH	Remove all sharp edges,burrs,slivers and swarf, break all edges 0.127-0.254mm. ZINC PLATING WITH 8um MICRONS MINIMUM PLATING THICKNESS AND TRIVALENT CHROMATE PASSIVATION AND WITHSTAND 96 HRS TO WHITE / 144 HS TO RED RUST IN SALT SPRAY TEST. 去除所有毛刺, 铁屑等残留物, 锐边倒钝0.127-0.254mm. 镀锌, 三价铬钝化, 银白色, 盐雾试验96小时无白斑, 144小时无红锈, 镀锌层厚度大于8um.