

REV 更改号	DATE 日期	REVISION DETAILS 更改内容	APPD 审核并批准
A	Jun.28,2019	Drawing Update	

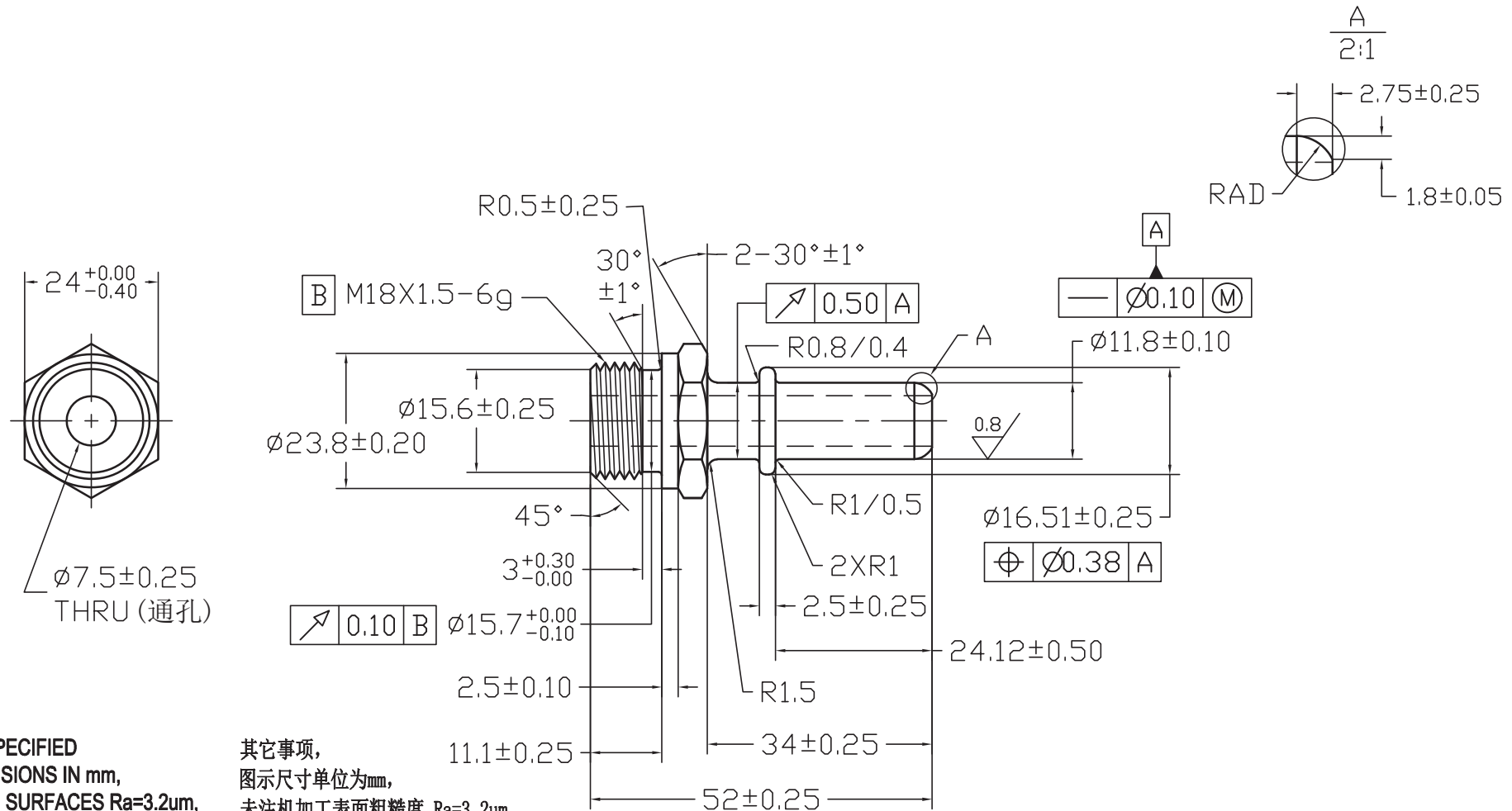

UNLESS SPECIFIED  
ALL DIMENSIONS IN mm,  
MACHINED SURFACES Ra=3.2um,  
ANGLE TOLERANCES±5°,  
Other tolerance except angles,  
in accordance with  
GB/T1804-2000(ISO2768-1)-m  
and GB/T1184-1996(ISO2768-2)-m

其它事项,  
图示尺寸单位为mm,  
未注机加工表面粗糙度 Ra=3.2um,  
未注角度公差 ±5° ,  
其它未注公差 (除角度外) 均按:  
GB/T1804-2000(ISO2768-1)-m 和  
GB/T1184-1996(ISO2768-2)-m

去除所有毛刺, 铁屑等残留物, 锐边倒钝0.127-0.254mm.

镀锌, 三价铬钝化, 银白色, 盐雾试验96小时无白斑, 144小时无红锈, 镀锌层厚度大于8um.

Zhejiang Gaocheng Autoparts Co.,Ltd	
PART No 零件名	40679-M18-12QC
SCALE:	APPD: 批准
DATE: 日期	DRN: 制图
NTS	CHK: 审核
	Pan 2019.06.28
	Pan 2019.06.28

MATERIAL Chinese steel 45

FINISH Remove all sharp edges, burrs, slivers and swarf, break all edges 0.127-0.254mm.  
ZINC PLATING WITH 8um MICRONS MINIMUM PLATING THICKNESS AND TRIVALENT CHROMATE PASSIVATION  
AND WITHSTAND 96 HRS TO WHITE / 144 HS TO RED RUST IN SALT SPRAY TEST.