

REV 更改号	DATE 日期	REVISION DETAILS 更改内容	APPD 审核并批准
A	2017.03.02	PRODUCTION ISSUE	

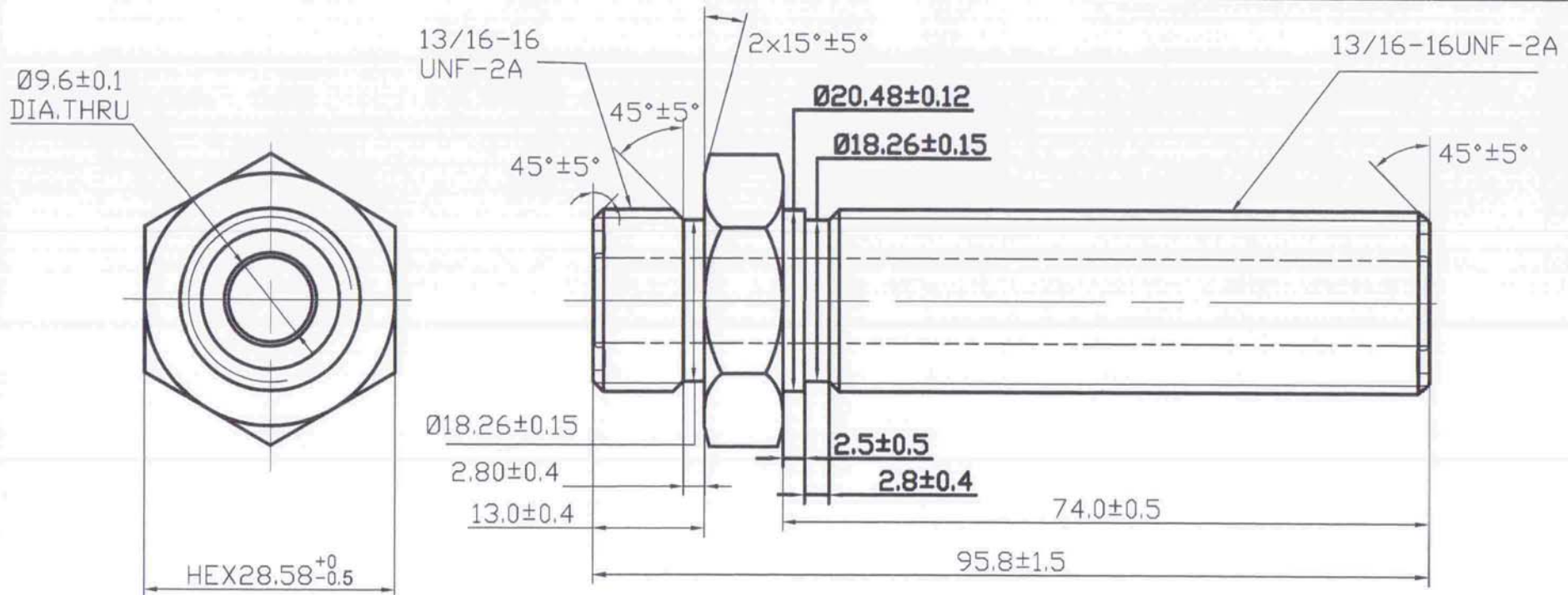

UNLESS SPECIFIED  
ALL DIMENSIONS IN mm,  
MACHINED SURFACES  $Ra=3.2\mu\text{m}$ ,  
ANGLE TOLERANCES  $\pm 1^\circ$ ,  
Other tolerance except angles,  
in accordance with  
GB/T1804-2000(ISO2768-1)-m and  
GB/T1184-1996(ISO 2768-2)-m

其它事项  
图示尺寸单位为mm  
未注机加工表面粗糙度为 $Ra=3.2$   
未注角度公差 $\pm 1^\circ$   
其它未注公差(除角度外)均按:  
GB/T1804-2000(ISO2768-1)-M和  
GB/T1184-1996(ISO 2768-2)-m

材质: 45#

去除所有毛刺, 铁销等残留物, 锐边倒钝 $0.127-0.254\text{mm}$   
镀锌, 三价铬钝化, 银白色, 盐雾试验96小时无白斑。  
144小时无红锈, 镀锌层厚度大于 $12\mu\text{m}$ 。

[REDACTED]			
PART NO 零件名		41048-8FS-8FSBH	
SCALE NTS	APPD: 批准: Zhang	DRN 制图: KEVIN	DATE 日期: 2017.03.02
	DATE 日期: 06/03/17	CHK 审核: YB. ZHAN	DATE 日期: 2017.03.02

MATERIAL	Chinese steel 45	材质: 45#
FINISH	Remove all sharp edges, burns, slivers and swarf, break all edges $0.127-0.254\text{mm}$ . zinc plating with 12um microns minimum plating thickness and trivalent chromate passivation and withstand 96 HRS to white/144 HS to red rust in salt spray test.	去除所有毛刺, 铁销等残留物, 锐边倒钝 $0.127-0.254\text{mm}$ 镀锌, 三价铬钝化, 银白色, 盐雾试验96小时无白斑。 144小时无红锈, 镀锌层厚度大于 $12\mu\text{m}$ 。