

REV 更改号	DATE 日期	REVISION DETAILS 更改内容	APPD 审核并批准
A	Dec.4,2016	Change the part number	
B	Jun.30,2019	Change Dia.8.38±0.08 to 8.4±0.10	

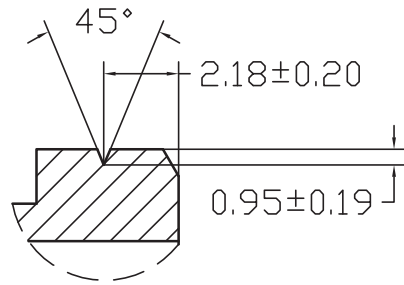

DETAIL A  
(细节 A)

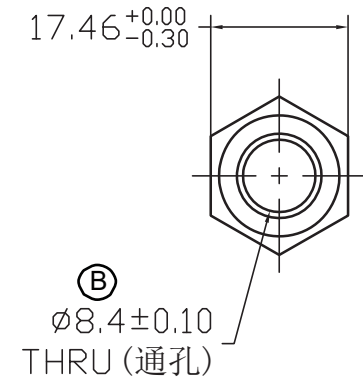
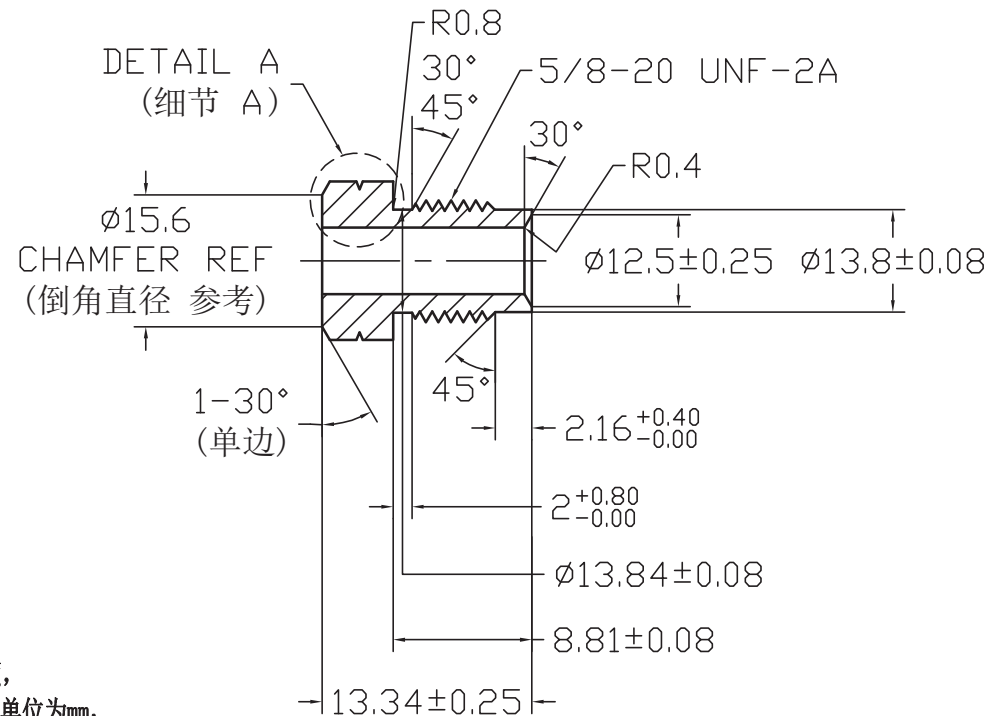

UNLESS SPECIFIED  
ALL DIMENSIONS IN mm,  
MACHINED SURFACES Ra=3.2um,  
ANGLE TOLERANCES ±5° ,  
Other tolerance except angles,  
in accordance with  
GB/T1804-2000(ISO2768-1)-m  
and GB/T1184-1996(ISO2768-2)-m

其它事项,  
图示尺寸单位为mm,  
未注机加工表面粗糙度 Ra=3.2um,  
未注角度公差 ±5° ,  
其它未注公差 (除角度外) 均按:  
GB/T1804-2000(ISO2768-1)-m 和  
GB/T1184-1996(ISO2768-2)-m

MATERIAL Chinese steel 45

FINISH Remove all sharp edges, burrs, slivers and swarf, break all edges 0.127-0.254mm.  
ZINC PLATING WITH 8um MICRONS MINIMUM PLATING THICKNESS AND TRIVALENT CHROMATE PASSIVATION  
AND WITHSTAND 96 HRS TO WHITE / 144 HS TO RED RUST IN SALT SPRAY TEST.

去除所有毛刺, 铁屑等残留物, 锐边倒钝0.127-0.254mm.  
镀锌, 三价铬钝化, 银白色, 盐雾试验96小时无白斑, 144小时无红锈, 镀锌层厚度大于8um.

Zhejiang Gaocheng Autoparts Co.,Ltd			
PART No 零件名	41192-MS-05 (MS3050-5)		
SCALE:	APPD: 批准	DRN: 制图	Pan 2019.06.30
NTS	DATE: 日期	CHK: 审核	Pan 2019.06.30