

REV 更改号	DATE 日期	REVISION DETAILS 更改内容	APPD 审核并批准
A	May.06.2022	Production issue	
B	Jun.20.2022	Delete the chamfer 15°	
C	Jun.22.2022	Change 40.6 to 40.5	<i>WJH</i>

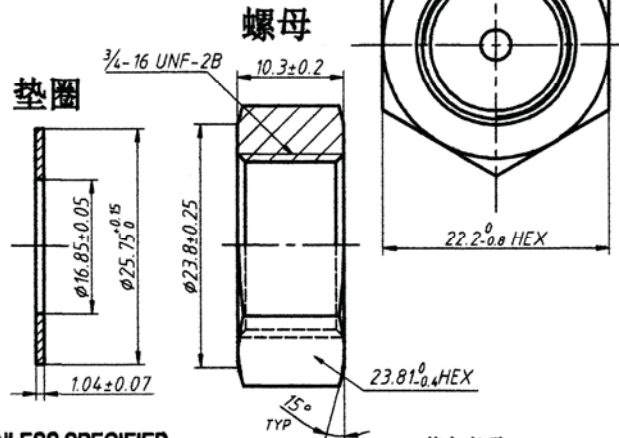

UNLESS SPECIFIED
ALL DIMENSIONS ARE IN mm,
ROUGHNESS ON
HEXAGON SURFACE ∇ ,
INNER SURFACE OF THE BORE
BETWEEN Ra6.2 um AND Ra12.5um,
OTHER MACHINED SURFACE Ra3.2um,
ANGLES TOLERANCE $\pm 5^\circ$,
DIMENSIONS TOLERANCE ± 0.25 mm,
REMOVE ALL BURRS,SLIVERS AND SWARF,
BREAK ALL SHARP EDGES R<0.5mm.

其它事项,
图示尺寸单位为mm,
六角面粗糙度 ∇ ,
内孔表面粗糙度 Ra6.2-Ra12.5,
其它未注机加工表面粗糙度 Ra=3.2um,
未注角度公差 $\pm 5^\circ$,
未注尺寸公差 ± 0.25 mm
去除所有毛刺及金属切屑,
锐边倒钝R<0.5mm.

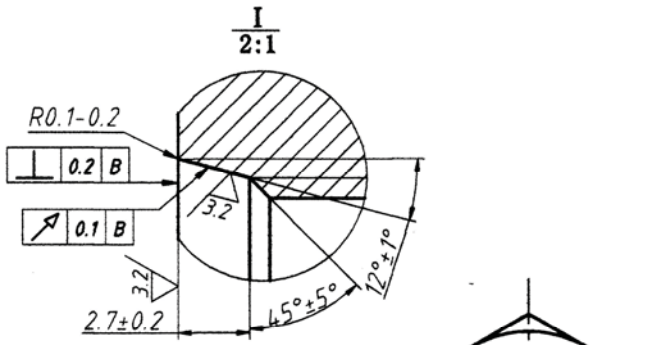
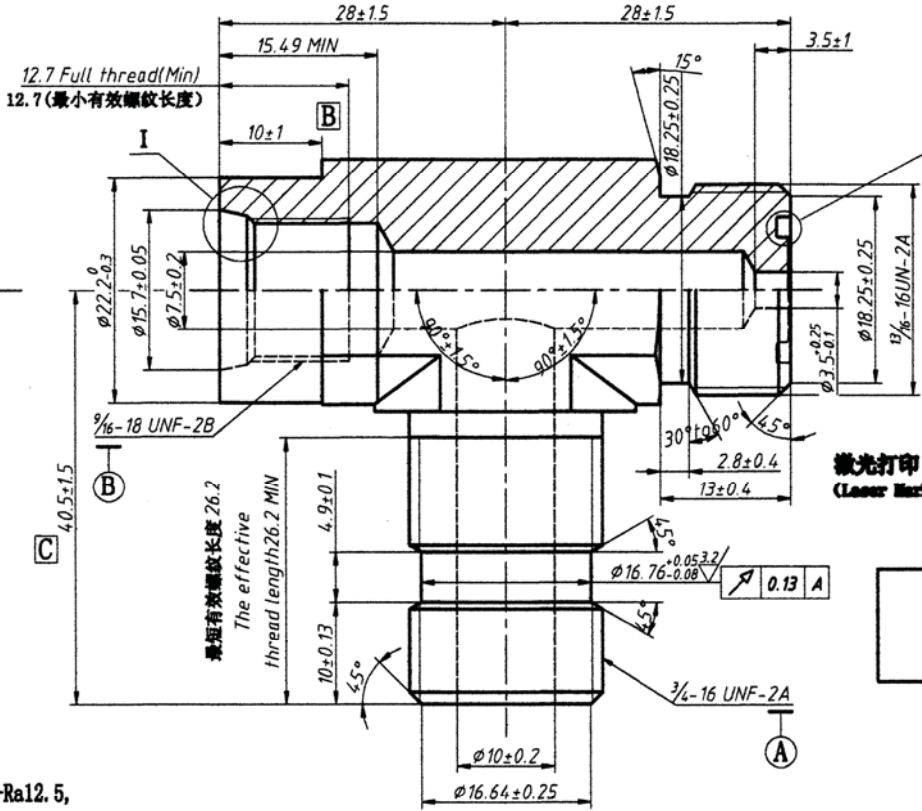

SEE SAE J1453-1
REVISED MAY2012

激光打印 "R-3.5" 字高3 最小
(Laser Marking "R-3.5", Size Min 3.0mm)

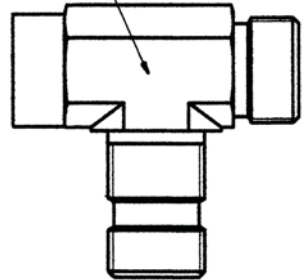

Zhejiang Gaocheng Autoparts Co.,Ltd	
PART No 零件名	41239-8FS-6PT-8NWO-R3.5
SCALE:	APPD: 余德胜 批准: <i>EL</i> 制图: 2022.06.22
NTS	DATE: 22/6/22 日期: 2022.06.22 CHK: 詹永斌 审核: <i>WJH</i>

MATERIAL	Chinese steel 45#	材料 45号钢
FINISH	Remove all sharp edges,burrs,slivers and swarf, break all edges 0.127-0.254mm. ZINC PLATING WITH 8um MICRONS MINIMUM PLATING THICKNESS AND TRIVALENT CHROMATE PASSIVATION AND WITHSTAND 96 HRS TO WHITE / 144 HS TO RED RUST IN SALT SPRAY TEST.	去除所有毛刺, 铁屑等残留物, 锐边倒钝0.127-0.254mm. 镀锌, 三价铬钝化, 银白色, 盐雾试验96小时无白斑, 144小时无红锈, 镀锌层厚度大于8um.

