

REV 更改号	DATE 日期	REVISION DETAILS 更改内容	APPD 审核并批准
A	Mar. 23, 2022	Production issue	
B	Mar.23,2022	Change "stainless steel" to "steel"	

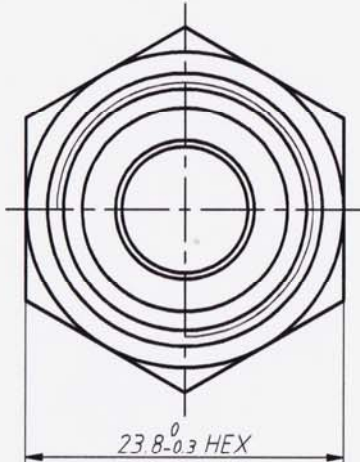

SEE SAE J1453-1
REVISED MAY2012

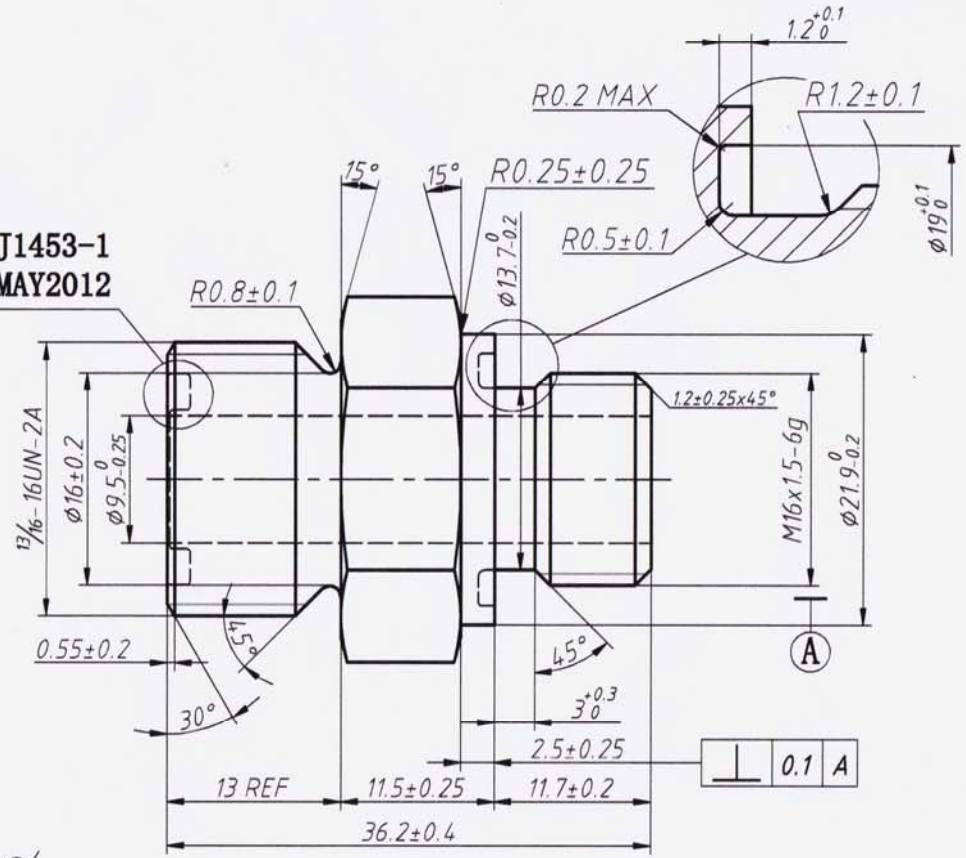

UNLESS SPECIFIED
ALL DIMENSIONS ARE IN mm,
ROUGHNESS ON
HEXAGON SURFACE
INNER SURFACE OF THE BORE
BETWEEN Ra6.2 um AND Ra12.5um,
OTHER MACHINED SURFACE Ra3.2um,
ANGLES TOLERANCE ±5°,
DIMENSIONS TOLERANCE ±0.25mm,
REMOVE ALL BURRS,SLIVERS AND SWARF,
BREAK ALL SHARP EDGES R<0.5mm.

其它事项,
图示尺寸单位为mm,
六角面粗糙度 ,
内孔表面粗糙度Ra6.2-Ra12.5,
其它未注机加工表面粗糙度 Ra=3.2um,
未注角度公差 ±5',
未注尺寸公差 ±0.25mm
去除所有毛刺及金属切屑,
锐边倒钝R<0.5mm.

THIRD ANGLE PROJECTION

Zhejiang Gaocheng Autoparts Co.,Ltd

MATERIAL Chinese steel 20# B

材料 20号钢

PART No 零件名 41482-STR-8FS-M16E0

FINISH Remove all sharp edges,burrs,slivers and swarf, break all edges 0.127-0.254mm.
ZINC PLATING WITH 8um MICRONS MINIMUM PLATING THICKNESS AND TRIVALENT CHROMATE PASSIVATION AND WITHSTAND 96 HRS TO WHITE / 144 HS TO RED RUST IN SALT SPRAY TEST.

去除所有毛刺, 铁屑等残留物, 锐边倒钝0.127-0.254mm.
镀锌, 三价铬钝化, 银白色, 盐雾试验96小时无白斑, 144小时无红锈, 镀锌层厚度大于8um.

SCALE: 批准 *re* APPD: 余德胜 2022.03.23
DATE: 日期 *EL* CHK: 詹永斌 2022.03.23
NTS 审核