

图纸正确。2013年1月13日

明 健

REV	DATE	REVISION DETAILS	APPD

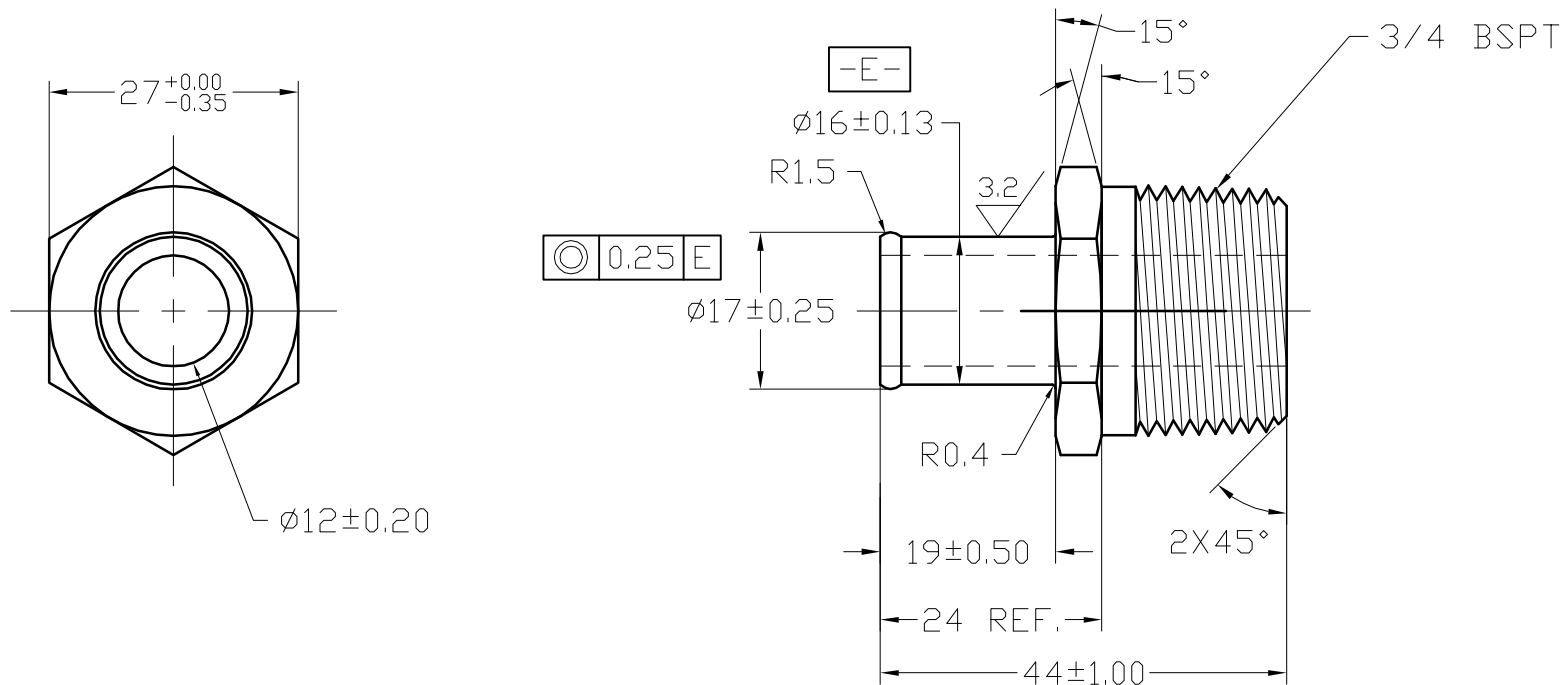

UNLESS SPECIFIED
 ALL DIMENSIONS IN mm
 MACHINED SURFACES Ra=3.2um
 ANGLE TOLERANCES ±1°
 DECIMAL TOLERANCES:
 .x: ±0.5
 .xx: ±0.25
 .xxx ±0.127

PART No		4404-10-R12	
SCALE:	APPD:	DRN:	
NTS	L. G. Pan	L. G. Pan	
	DATE:	CHK:	
	2013. 01. 11	L. G. Pan	

MATERIAL	Chinese steel 45		
FINISH	Remove all sharp edges, burrs, slivers and swarf, break all edges 0.127-0.254mm. ZINC PLATED WITH TRIVALENT CHROMATE AND NO RED CORROSION IN 96 HOURS SALT SPRAY TEST.	去除所有毛刺, 铁屑等残留物, 锐边倒钝0.127 0.254mm. 镀三价铬锌, 银白色, 96小时盐雾试验无红斑.	