

REV 更改号	DATE 日期	REVISION DETAILS 更改内容	APPD 审核并批准
A	Jun.30,2019	Drawing Update	

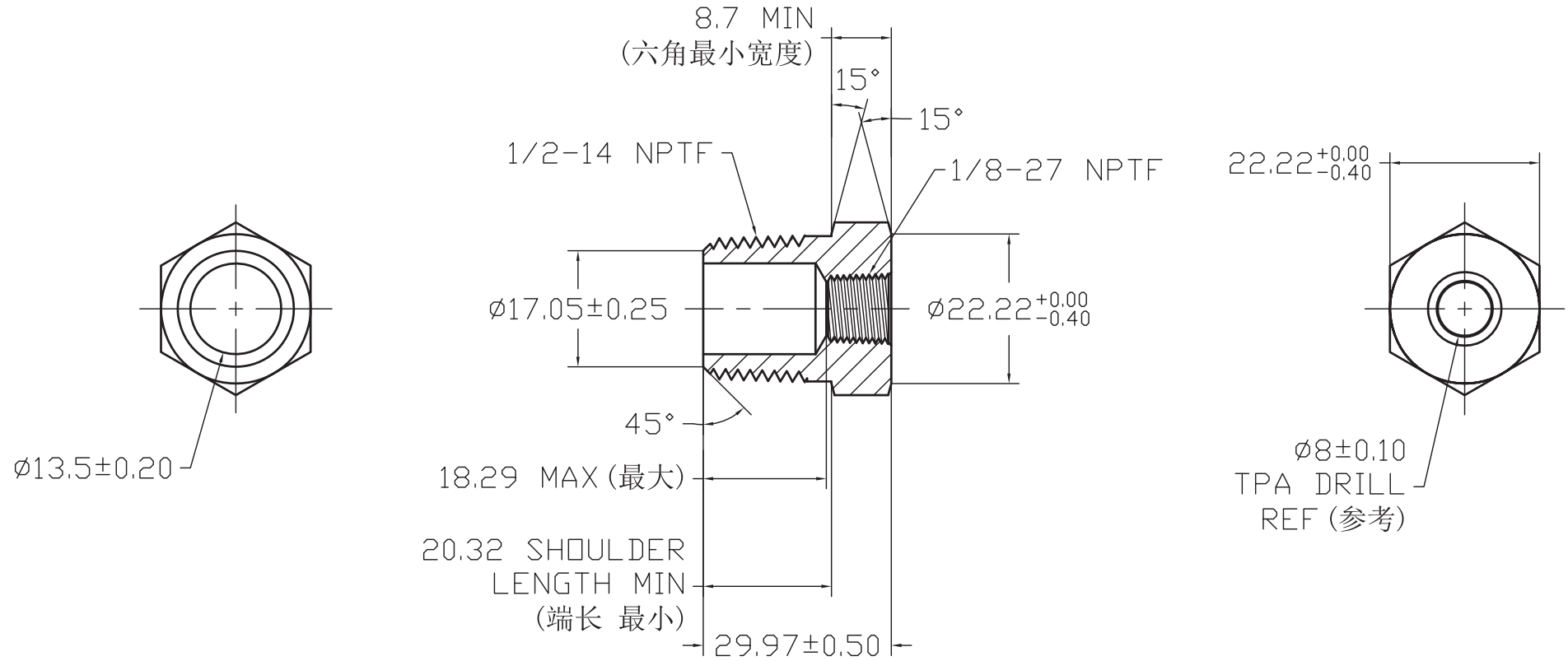

UNLESS SPECIFIED  
ALL DIMENSIONS IN mm,  
MACHINED SURFACES Ra=3.2um,  
ANGLE TOLERANCES ±5° ,  
Other tolerance except angles,  
in accordance with  
GB/T1804-2000(ISO2768-1)-m  
and GB/T1184-1996(ISO2768-2)-m

其它事项,  
图示尺寸单位为mm,  
未注机加工表面粗糙度 Ra=3.2um,  
未注角度公差 ±5° ,  
其它未注公差 (除角度外) 均按:  
GB/T1804-2000(ISO2768-1)-m 和  
GB/T1184-1996(ISO2768-2)-m

MATERIAL	Chinese steel 45
FINISH	Remove all sharp edges,burrs,slivers and swarf, break all edges 0.127-0.254mm. ZINC PLATING WITH 8um MICRONS MINIMUM PLATING THICKNESS AND TRIVALENT CHROMATE PASSIVATION AND WITHSTAND 96 HRS TO WHITE / 144 HS TO RED RUST IN SALT SPRAY TEST. 去除所有毛刺, 铁屑等残留物, 锐边倒钝0.127-0.254mm. 镀锌, 三价铬钝化, 银白色, 盐雾试验96小时无白斑, 144小时无红锈, 镀锌层厚度大于8um.

Zhejiang Gaocheng Autoparts Co.,Ltd	
PART No 零件名	5406-8-2
SCALE:	APPD: 批准 DRN: Pan 制图 2019.06.30
NTS	DATE: 日期 CHK: Pan 审核 2019.06.30