

REV	DATE	REVISION DETAILS	APPD
序号	日期	变更内容	审核/批准
Ⓐ	2015.03.07	Ø12.95±0.13 改为 Ø13.5±0.13 Change Ø12.95±0.13 to Ø13.5±0.13	
Ⓑ	2020.01.07	Drawing Update	

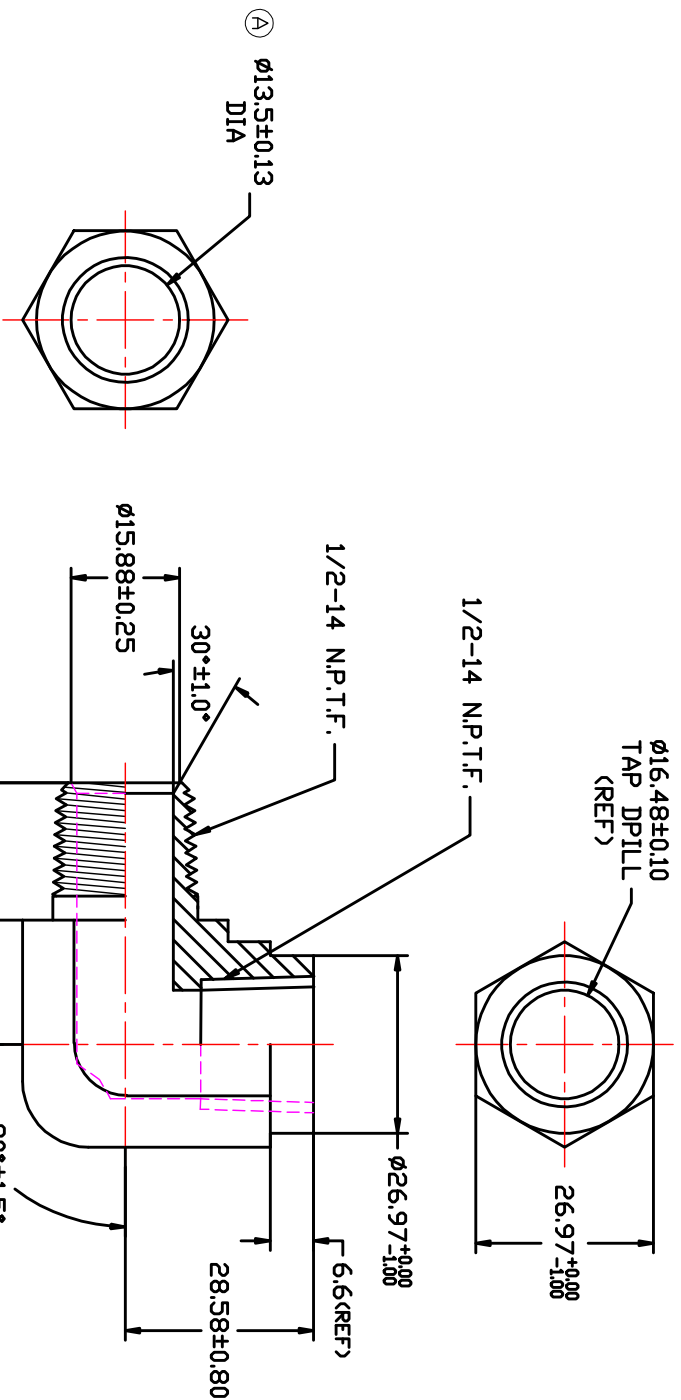

UNLESS SPECIFIED  
ALL DIMENSIONS IN mm,  
MACHINED SURFACES Ra=3.2um,  
ANGLE TOLERANCES ±5°,  
Other tolerance except angles,  
in accordance with  
GB/T1804-2000(ISO2768-1)-m  
and GB/T184-1996(ISO2768-2)-m

其它事项,  
图示尺寸单位为mm,  
未注机械加工表面粗糙度 Ra=3.2um,  
未注角度公差 ±5°,  
其它未注公差 (除角度外) 均按:  
GB/T1804-2000(ISO2768-1)-m 和  
GB/T184-1996(ISO2768-2)-m

<b>MATERIAL</b>		Chinese steel 45	
<b>FINISH</b>		Remove all sharp edges/surfaces and sharp break of edges 0.27-0.254mm ZINC PLATING WITH PART MICRONS MINIMUM PLATING THICKNESS AND TRivalent Chromium PASSIVATION AND WITHstand 96 HRS TO WHITE / 144 HS TO RED RUST IN SALT SPRAY TEST.	
<b>Zhejiang Geocheng Autoparts Co., Ltd</b>			
<b>PART NO</b>		5502-8 LT	
<b>SCALE:</b>		<b>APPD:</b>	
NTS		批准	
<b>DATE:</b>		<b>日期:</b>	
NTS		2020.01.07	
<b>CHK:</b>		<b>审核:</b>	
NTS		Li Jumbiao	
<b>DATE:</b>		<b>日期:</b>	
NTS		2020.01.07	