

REV	DATE	REVISION DETAILS	APPD
更改号	日期	更改内容	审核并批准
A	Mar. 30 2020	Drawing Update	

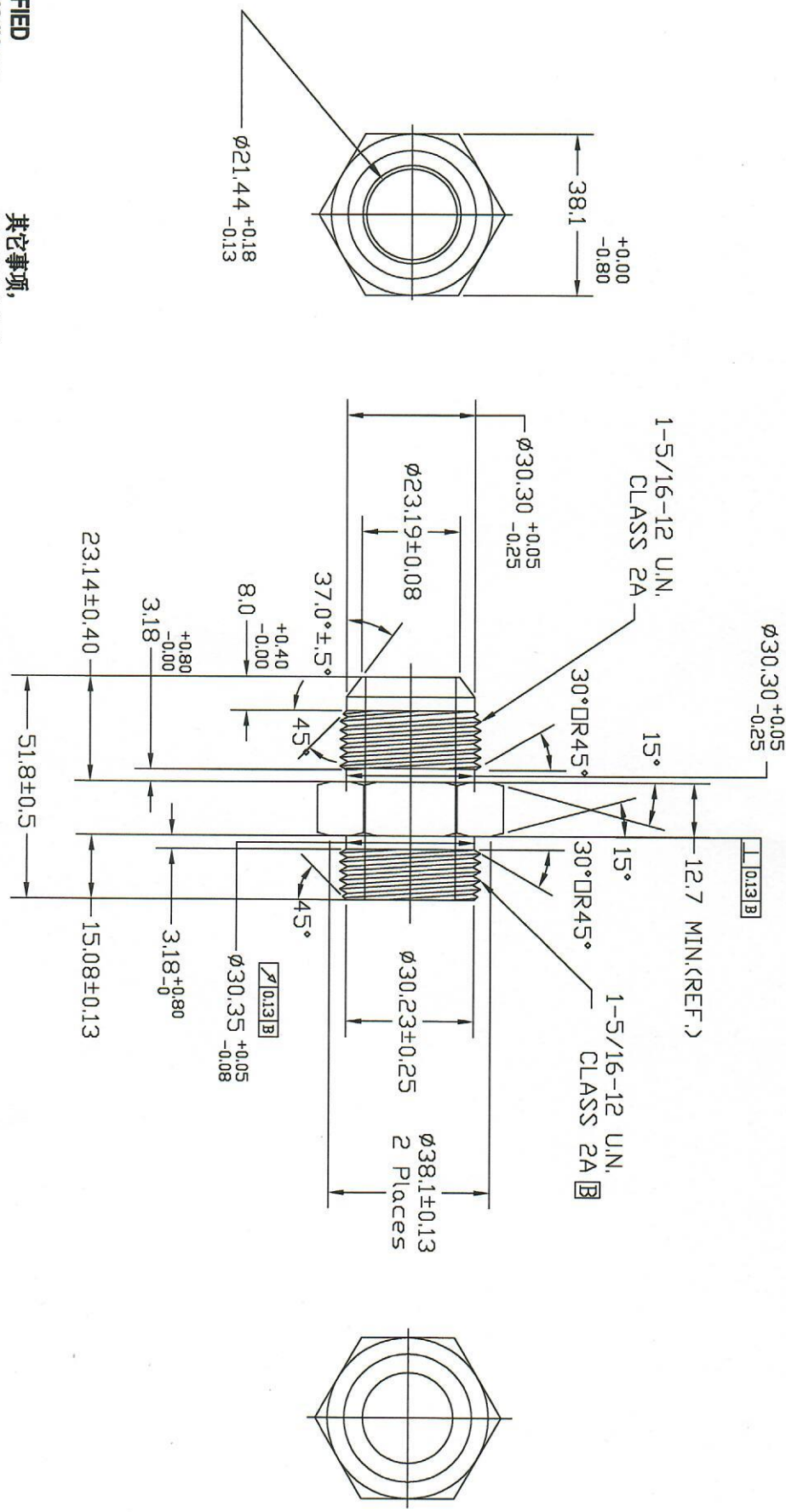

UNLESS SPECIFIED
ALL DIMENSIONS IN mm,
MACHINED SURFACES Ra=3.2um,
ANGLE TOLERANCES ±5°,
Other tolerance except angles,
in accordance with
GB/T1804-2000(ISO2768-1)-m
and GB/T1184-1996(ISO2768-2)-m

其它事项,
图示尺寸单位为mm,
未注机加工表面粗糙度 Ra=3.2um,
未注角度公差 ±5°,
其它未注公差 (除角度外) 均按:
GB/T1804-2000(ISO2768-1)-m 和
GB/T1184-1996(ISO2768-2)-m

Zhejiang Gaocheng Autoparts Co., Ltd	
PART No 零件名	6400-16

MATERIAL	Chinese steel 45
FINISH	Remove all sharp edges,burrs,sifvers and swarf, break all edges 0.127-0.254mm, ZINC PLATING WITH 8um MICRONS MINIMUM PLATING THICKNESS AND TRIVALENT CHROMATE PASSIVATION AND WITHSTAND 96 HRS TO WHITE / 144 HS TO RED RUST IN SALT SPRAY TEST. 镀锌 三价铬钝化, 镀锌层厚度大于0.127-0.254mm, 镀锌层厚度大于0.127-0.254mm, 镀锌层厚度大于0.127-0.254mm, 镀锌层厚度大于0.127-0.254mm
SCALE:	NTS
DATE:	日期
CHK:	审核
DRN:	制图
DATE:	20.03.30
CHK:	Li Junbiao
DATE:	20.03.30