

REV	DATE	REVISION DETAILS	APPD
更改号	日期	更改内容	审核并批准
A	Mar.26.2020	Drawing Update	

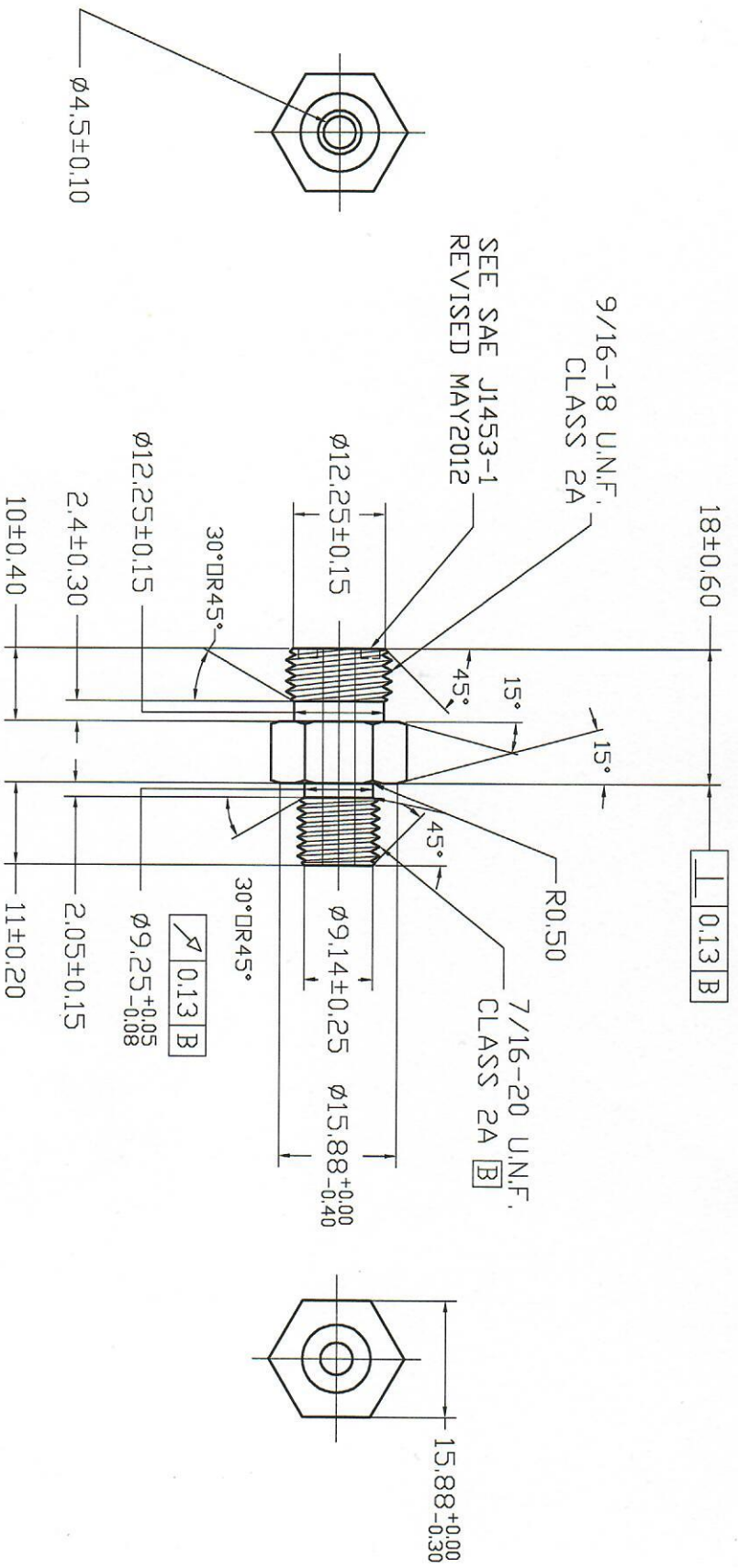

SEE SAE J1453-1  
REVISED MAY2012

7/16-20 U.N.F.  
CLASS 2A B

9/16-18 U.N.F.  
CLASS 2A

**UNLESS SPECIFIED**  
ALL DIMENSIONS IN mm,  
MACHINED SURFACES Ra=3.2um,  
ANGLE TOLERANCES ±5°,  
Other tolerance except angles,  
In accordance with  
GB/T1804-2000(ISO2768-1)-m  
and GB/T1184-1996(ISO2768-2)-m

其它事项,  
图示尺寸单位为mm,  
未注机械加工表面粗糙度 Ra=3.2um,  
未注角度公差 ±5°,  
其它未注公差 (除角度外) 均按:  
GB/T1804-2000(ISO2768-1)-m 和  
GB/T1184-1996(ISO2768-2)-m

<b>MATERIAL</b>	Chinese steel 45
<b>FINISH</b>	Remove all sharp edges,burrs,sivers and swarf, break all edges 0.127-0.254mm. ZINC PLATING WITH 8um MICRONS MINIMUM PLATING THICKNESS AND TRIVALENT CHROMATE PASSIVATION AND WITHSTAND 96 HRS TO WHITE / 144 HS TO RED RUST IN SALT SPRAY TEST. 镀锌, 三价铬钝化, 银白色, 盐雾试验96小时无白斑, 144小时无红锈, 镀锌层厚度大于9um 去除所有毛刺, 倒圆等缺陷, 锐边倒钝0.127-0.254mm

<b>Zhejiang Gaocheng Autoparts Co.,Ltd</b>	
<b>PART No</b> 零件名	6400-04FS-04
<b>SCALE:</b>	NTS
<b>DATE:</b> 日期	20.03.26
<b>CHK:</b> 审核	Li Junbiao
<b>APPD:</b> 批准	Sun Jianguan
<b>DRN:</b> 制图	20.03.26