

REV	DATE	REVISION DETAILS	APPD
更改号	日期	更改内容	审核并批准
A	Mar.26.2020	Drawing Update	

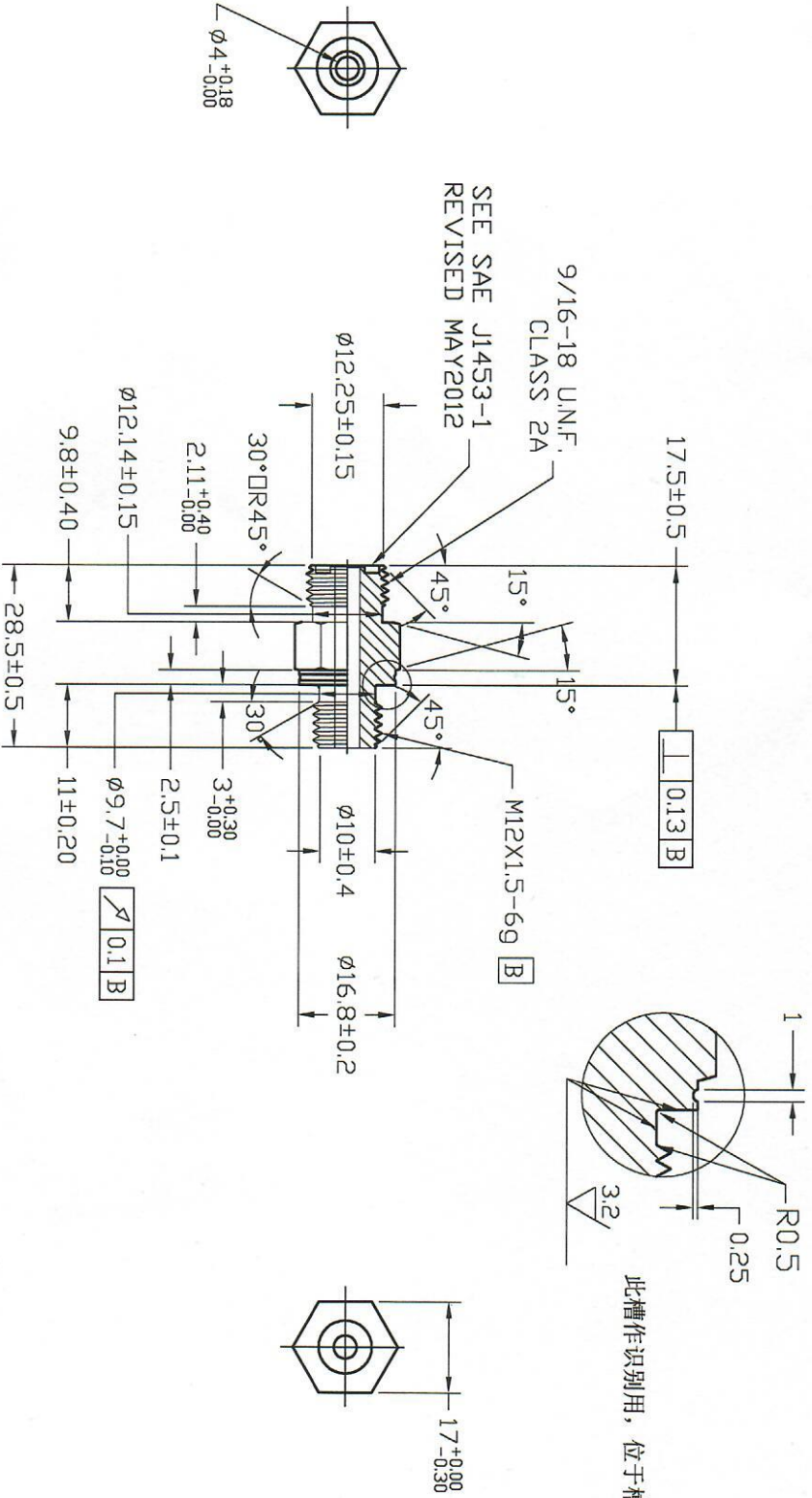

UNLESS SPECIFIED
ALL DIMENSIONS IN mm,
MACHINED SURFACES Ra=3.2µm,
ANGLE TOLERANCES ±5°,
Other tolerance except angles,
in accordance with
GB/T1804-2000(ISO2768-1)-m
and GB/T1184-1996(ISO2768-2)-m

其它事项,
图示尺寸单位为mm,
未注机械加工表面粗糙度 Ra=3.2µm,
未注角度公差 ±5°,
其它未注公差 (除角度外) 均按:
GB/T1804-2000(ISO2768-1)-m 和
GB/T1184-1996(ISO2768-2)-m

MATERIAL Chinese steel 45

FINISH Remove all sharp edges,burrs,sivers and swarf, break all edges 0.127~0.254mm. ZINC PLATING WITH 8µm MICRONS MINIMUM PLATING THICKNESS AND TRIVALENT CHROMATE PASSIVATION AND WITHSTAND 96 HRS TO WHITE / 144 HS TO RED RUST IN SALT SPRAY TEST.

去除所有毛刺, 倒角等缺陷, 破边倒角0.127~0.254mm. 镀锌, 三价铬钝化, 银白色, 盐雾试验96小时无白斑, 144小时无红锈, 镀锌层厚度大于8µm.

Zhejiang Gaocheng Autoparts Co.,Ltd	
PART No 零件名	6400-04FS-M12
SCALE: NTS	APPD: 批准
DATE: 日期	DRN: Sun Jianguan 制图 20.03.26
	CHK: Li Junbiao 审核 20.03.26