

LOCKNUT

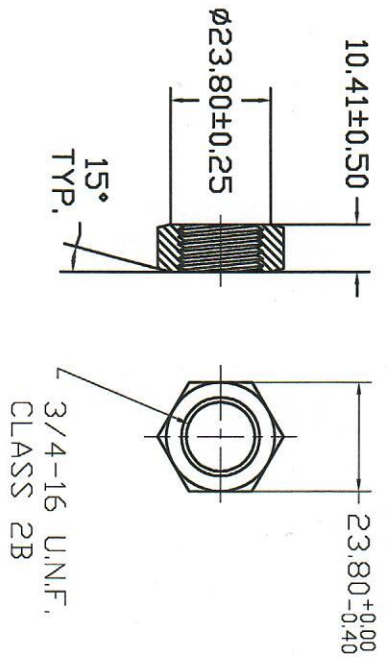

WASHER

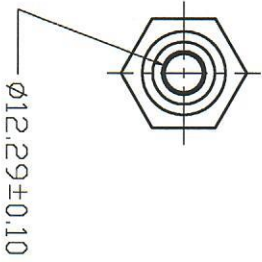
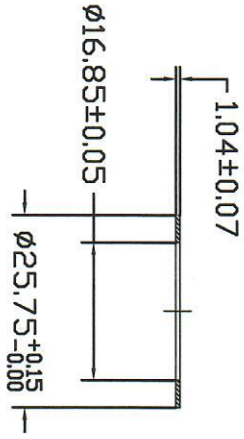

SEE SAE J1453-1
REVISED MAY2012

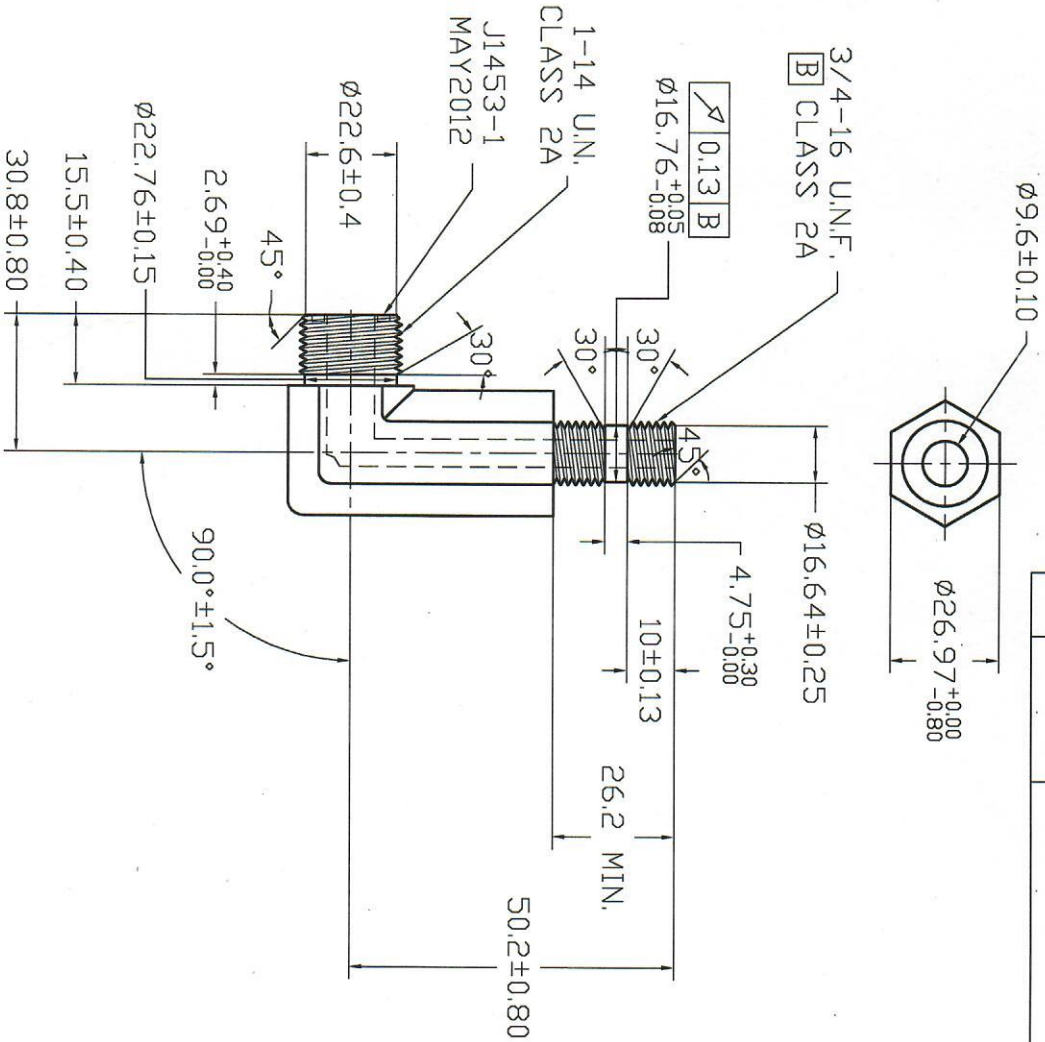

UNLESS SPECIFIED

ALL DIMENSIONS IN mm,
MACHINED SURFACES Ra=3.2um,
ANGLE TOLERANCES ±5°,
Other tolerance except angles,
in accordance with
GB/T1804-2000(ISO2768-1)-m
and GB/T1184-1996(ISO2768-2)-m

其它事项,
图示尺寸单位为mm,
未注机加工表面粗糙度 Ra=3.2um,
未注角度公差 ±5°,
其它未注公差 (除角度外) 均按:
GB/T1804-2000(ISO2768-1)-m 和
GB/T1184-1996(ISO2768-2)-m

MATERIAL

Chinese steel 45

FINISH

Remove all sharp edges,burrs,sifters and swarf, break all edges 0.127-0.254mm.
ZINC PLATING WITH 8um MICRONS MINIMUM PLATING THICKNESS AND TRIVALENT CHROMATE PASSIVATION
AND WITHSTAND 96 HRS TO WHITE / 144 HS TO RED RUST IN SALT SPRAY TEST.

去除所有毛刺, 倒角等锐利物, 破边倒钝0.127-0.254mm.
镀锌, 三价铬钝化, 膜白色, 盐雾试验96小时无白锈, 144小时无红锈, 镀锌层厚度大于8um.

| REV | DATE | REVISION DETAILS | APPD |
|-----|--------------|------------------|-------|
| 更改号 | 日期 | 更改内容 | 审核并批准 |
| A | Mar 30, 2020 | Drawing Update | |

Zhejiang Gaocheng Autoparts Co., Ltd

PART No
零件名
6801-10FS-08NW/DL

SCALE:

NTS

APPD: Sum Jianghuan
批准
制图 20.03.30

DATE: 日期
CHK: Li Junbiao
审核 20.03.30