

REV 更改号	DATE 日期	REVISION DETAILS 更改内容	APPD 审核并批准
G,H,I	Jul.04,2019	Change 44.09 +0.18/0 to 44±0.40,Dia.15.47±0.13 to 15.5±0.20,Dia.21.44±0.18/-0.13 to Dia.21.4±0.20	

注：1. 不要装配O型圈；
2. 垫圈的装配要求松紧合适，即装配后用手可以轻松地移动垫圈，但不用手移动垫圈时，不论如何放置该零件，垫圈都不会任意滑动。

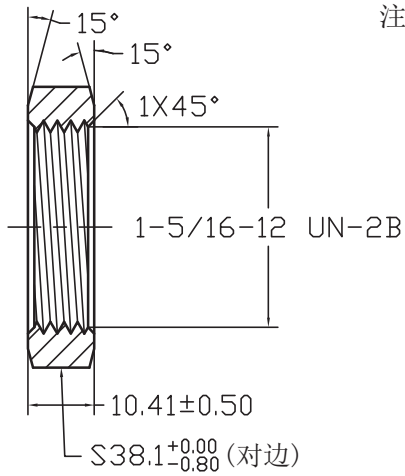

NUT
(螺母)

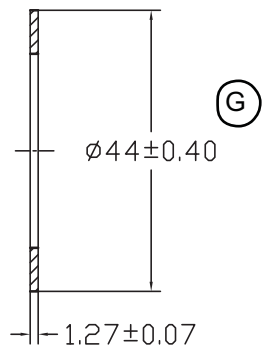

WASHER
(垫圈)

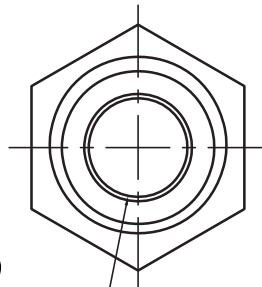

①
15.5±0.20

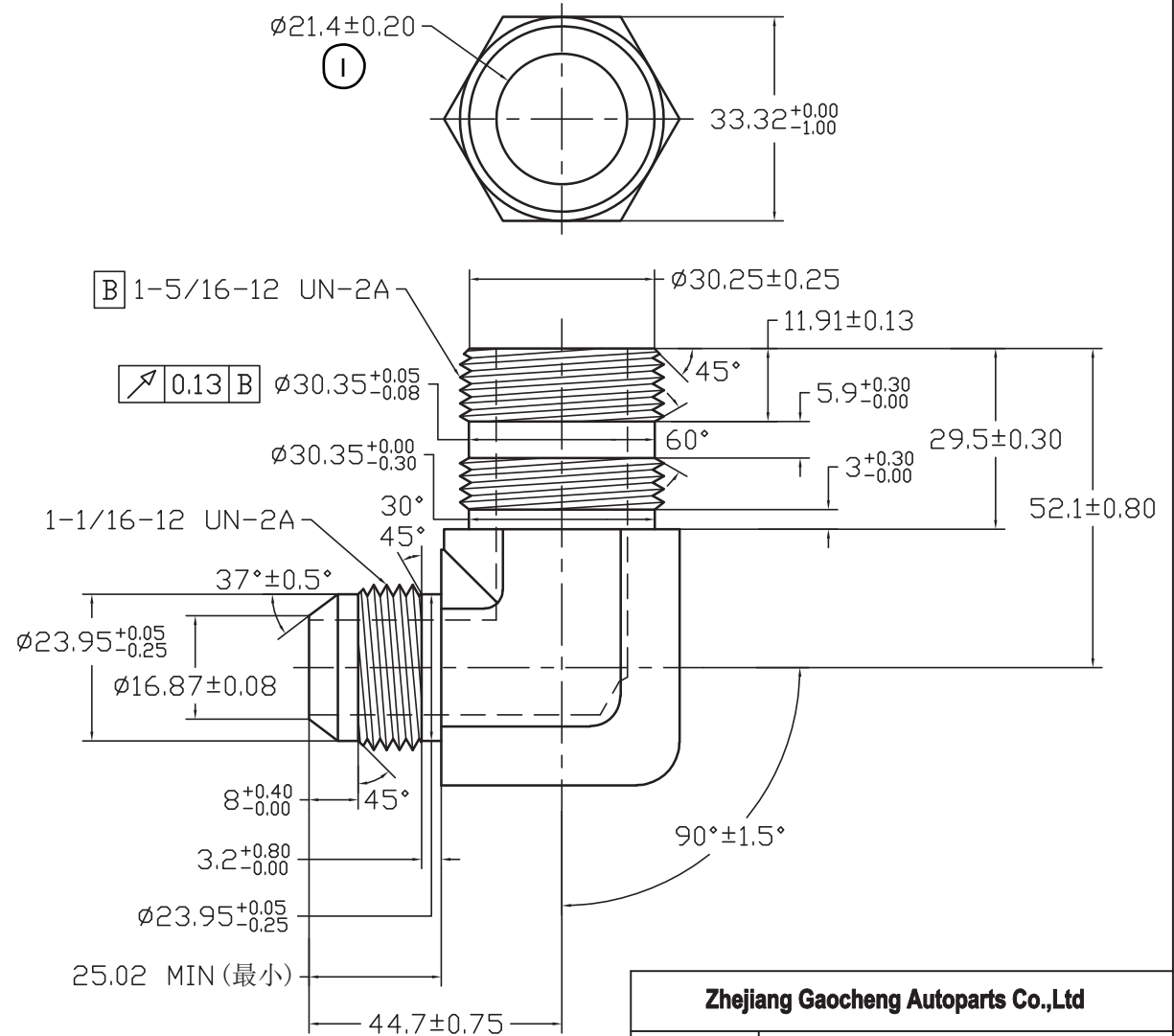

UNLESS SPECIFIED
ALL DIMENSIONS IN mm,
MACHINED SURFACES Ra=3.2um,
ANGLE TOLERANCES ±5° ,
Other tolerance except angles,
in accordance with
GB/T1804-2000(ISO2768-1)-m
and GB/T1184-1996(ISO2768-2)-m

其它事项,
图示尺寸单位为mm,
未注机加工表面粗糙度 Ra=3.2um,
未注角度公差 ±5° ,
其它未注公差 (除角度外) 均按:
GB/T1804-2000(ISO2768-1)-m 和
GB/T1184-1996(ISO2768-2)-m

Zhejiang Gaocheng Autoparts Co.,Ltd			
PART No 零件名	6801-12-16NWO		
SCALE:	APPD: 批准	DRN: 制图	Pan 2019.07.04
NTS	DATE: 日期	CHK: 审核	Pan 2019.07.04

MATERIAL Chinese steel 45

FINISH Remove all sharp edges,burrs,slivers and swarf, break all edges 0.127-0.254mm.
ZINC PLATING WITH 8um MICRONS MINIMUM PLATING THICKNESS AND TRIVALENT CHROMATE PASSIVATION
AND WITHSTAND 96 HRS TO WHITE / 144 HS TO RED RUST IN SALT SPRAY TEST.

去除所有毛刺, 铁屑等残留物, 锐边倒钝0.127-0.254mm.
镀锌, 三价钝化, 银白色, 盐雾试验96小时无白斑, 144小时无红锈, 镀锌层厚度大于8um.