

REV 更改号	DATE 日期	REVISION DETAILS 更改内容	APPD 审核并批准
A	Mar.27.2020	Drawing Update	

LOCKNUT

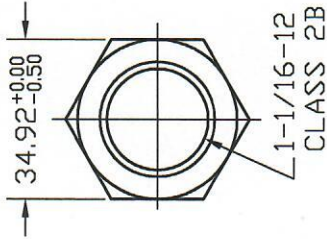

WASHER

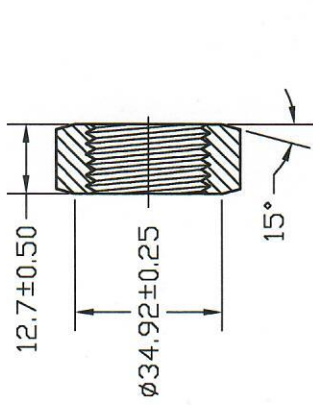
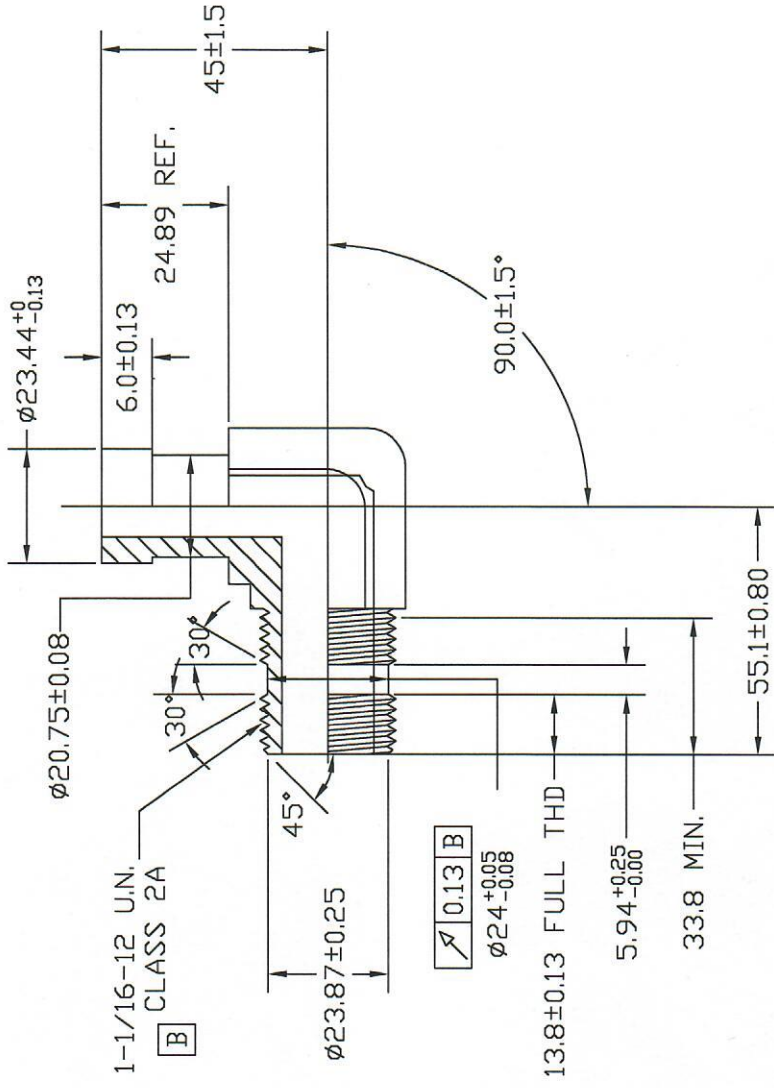
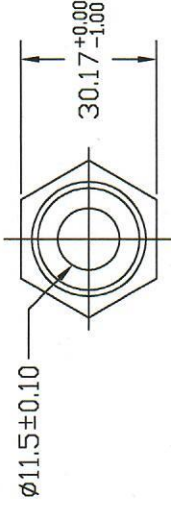
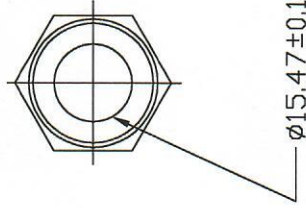
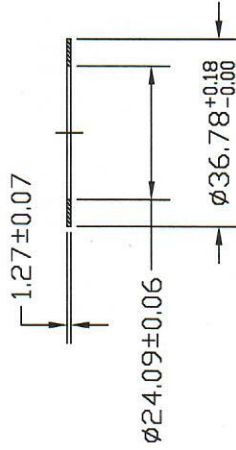

UNLESS SPECIFIED
 ALL DIMENSIONS IN mm,
 MACHINED SURFACES Ra=3.2um,
 ANGLE TOLERANCES ±5°,
 Other tolerance except angles,
 in accordance with
 GB/T1804-2000(ISO2768-1)-m
 and GB/T1184-1996(ISO2768-2)-m

其它事项,
 图示尺寸单位为mm,
 未注机加工表面粗糙度 Ra=3.2um,
 未注角度公差 ±5°,
 其它未注公差 (除角度外) 均按:
 GB/T1804-2000(ISO2768-1)-m 和
 GB/T1184-1996(ISO2768-2)-m

Zhejiang Gaocheng Autoparts Co.,Ltd

PART No
零件名 6809-12NW□-10F.S.W

MATERIAL Chinese steel 45

SCALE: NTS
 APPD: 批准
 DRN: Sun Jianguan
 制图 20.03.27
 DATE: 日期
 CHK: Li Junbiao
 审核 20.03.27

FINISH Remove all sharp edges,burrs,silvers and swarf, break all edges 0.127-0.254mm.
 ZINC PLATING WITH 8um MICRONS MINIMUM PLATING THICKNESS AND TRIVALENT CHROMATE PASSIVATION
 AND WITHSTAND 96 HRS TO WHITE / 144 HS TO RED RUST IN SALT SPRAY TEST.

去除所有毛刺, 铁屑等残留物, 锐边倒钝0.127-0.254mm.
 镀锌, 三价铬钝化, 银白色, 盐雾试验96小时无白斑, 144小时无红锈, 镀锌层厚度大于8um.