

图纸正确。 2012年12月3日

李健

REV	DATE	REVISION DETAILS	APPD
A	14/3/13	Production Issue	MJ

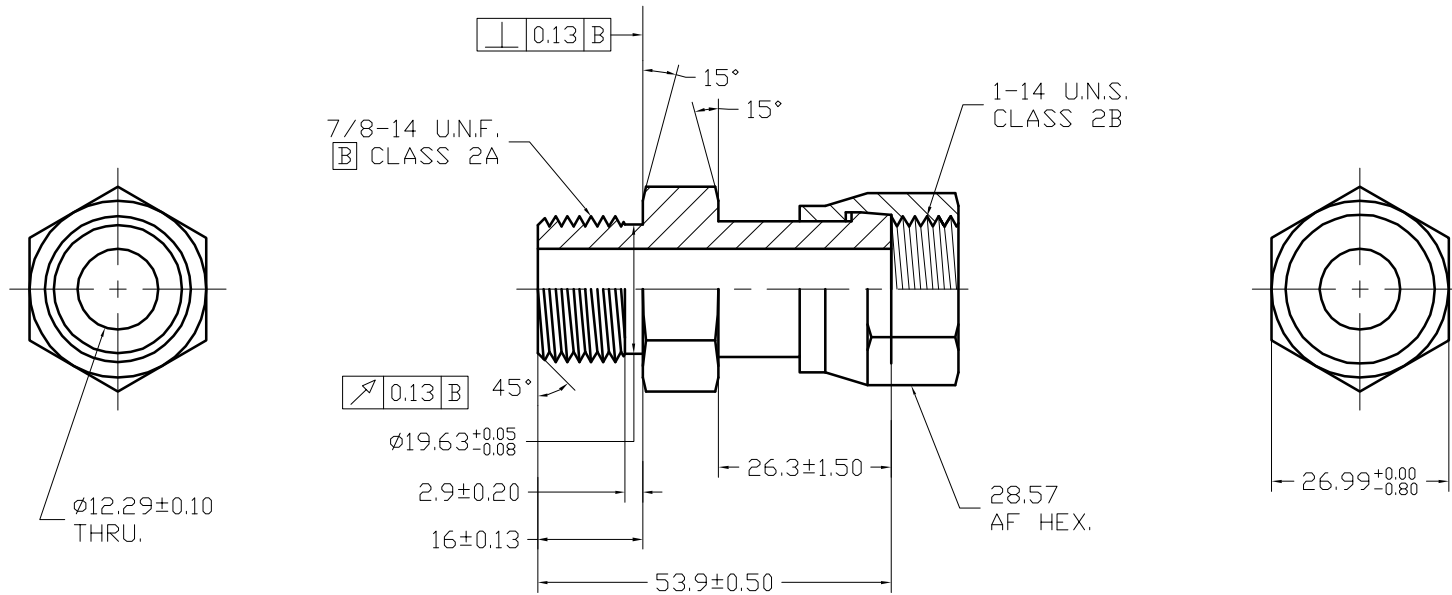

UNLESS SPECIFIED  
 ALL DIMENSIONS IN mm  
 MACHINED SURFACES Ra=3.2um  
 ANGLE TOLERANCES ±1°  
 DECIMAL TOLERANCES:  
 .x: ±0.5  
 .xx: ±0.25  
 .xxx ±0.127

HANGZHOU HI-TECH INDUSTRY IMP. & EXP. CORP.

PART No	6900-10FS-10	
SCALE:	APPD: L. G. Pan	DRN: L. G. Pan
NTS	DATE: 2012. 11. 15	CHK: L. G. Pan

MATERIAL	Chinese steel 45	
FINISH	Remove all sharp edges, burrs, slivers and swarf, break all edges 0.127-0.254mm. ZINC PLATED WITH TRIVALENT CHROMATE AND NO RED CORROSION IN 96 HOURS SALT SPRAY TEST.	去除所有毛刺, 铁屑等残留物, 锐边倒钝0.127 0.254mm. 镀三价铬锌, 银白色, 96小时盐雾试验无红斑.