

Operating Manual

(KLA/KLA-E/KLA-H)

Series A of Electric Counterbalanced Forklift

Jiangsu King-lift Equipment.,Ltd.

the First Edition of 2021

Notice: Before using this vehicle, each operator should read and comprehend this operating manual, as well as the related warning labels that are attached on the vehicle. The illustrated picture is only for reference, the benchmark is based on the real product.

Preface

Welcome to use this electric counterbalanced forklift made in King-lift company, China. This vehicle is made by special sectional material as designed compact as durable and easily-operated. For the sake of your safety and proper operation, please read and comprehend this operating manual, as well as the related warning labels that are attached on the vehicle, before using the forklift.

Notice: All the parameters of the manual is subject to this edition of this manual, King-lift company reserves the right to update its own products. The update will not be informed any more; please contact king-lift company if wanna know the latest parameters of products.

Notice: The forklift vehicle manufactured by King-lift company, under the terms of China Special Equipment safety surveillance, is only specially used in the indoor zones of factory, tourist attraction, pleasure ground, and so on.

Contents

1. Use Range
2. Operation Procedure
3. Safety Norm
4. Battery
5. Regular Failure & Troubleshooting
6. Upkeep & Maintenance
7. Electrical Schematic Diagram

1. Use Range

This series A of counterbalanced forklift is a warehousing forklift that is specially-designed for high-altitude stacking and transporting goods on even ground.

2. Operation Procedure

Start

Please operate by the procedure as follows, otherwise, the forklift will not work:

1. Ensure the plug inserts the power socket firmly.
2. Switch on emergency-switch, key-switch is at turn-on.
3. Ensure battery pack is of sufficient electric quantity.

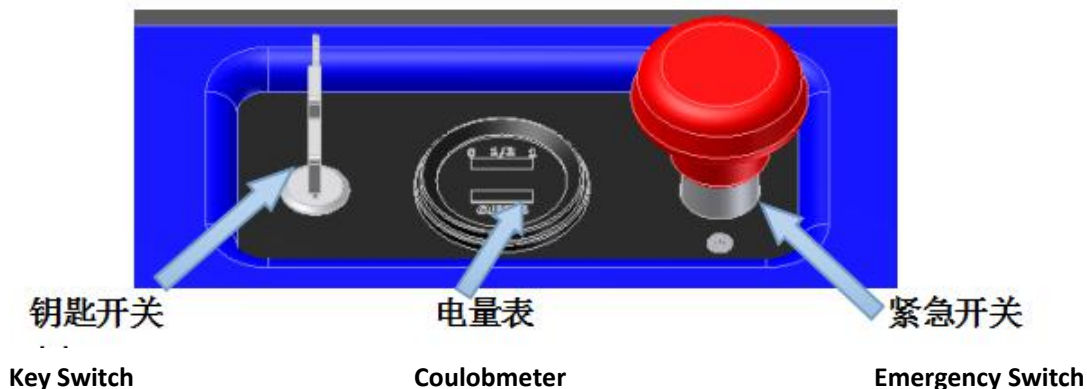

Attention !

Long-term operation by low electric potential will reduce battery life. Do not start the forklift before the completion of battery charging.

4. Steer at the correct direction, slowly accelerate the speed to the optimal speed

Notice !

Don't operate those forklifts that are dysfunctional and unsafe. First, check the following safety functions before everyday work.

- a) Check if horn is normal to work
- b) Check if steering is normal to work
- c) Check if brake is normal to work
- d) Check if hydraulic system is normal to work

Braking

1. The forklift performs braking as the control handle steers at the top or the lowest.
2. It operates electric braking when direction-switch turns to the reverse while normal travelling. 删了
3. Let it go back to neutral gear by loosening the travel-direction-switch to stop the

travel of the forklift.

Turning

1. The turning is controlled by the steering handle, the steering angle is on anywhere from left 90° to right 90°
2. Should not go forcibly through a barrier that is in front of the forklift, may turn the steering handle to bypass it forwards or backwards.

Notice !

Wheels are not allowed to slip.

If the operator's hands and shoes are oily, easily makes misoperation to cause the forklift out of control, so must wipe and dry the hands and shoes before driving the vehicle.

Parking

1. Release direction switch
2. Release the steering handle that will be back itself to the braking status.
3. Lower the forks to the lowest and release oil pressure out of hydraulic system.
4. Turn Key-switch to turn-off

Control Handler

控制手柄

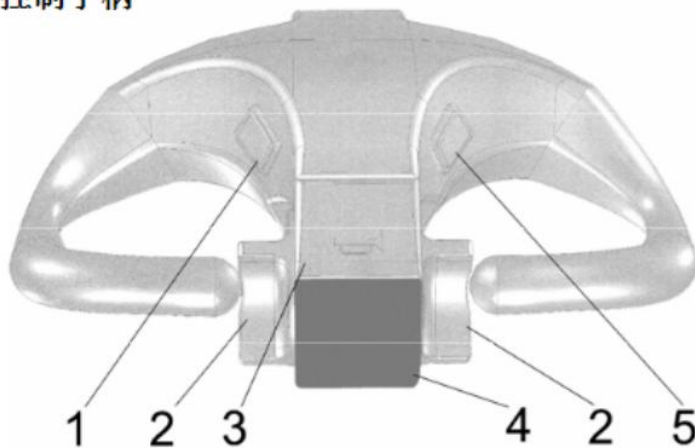

- 1 下降按钮
- 2 前进/后退 旋钮
- 3 喇叭按钮
- 4 肚皮开关
- 5 起升按钮

1. Lowering Button, 2. Forward/Backward Knob, 3. Horn Button, 4. Reverse Emergency Switch, 5. Lifting Button.

Notice !

1. Don't permit to operate the vehicle without authorization.
2. Please keep the key away with you when you leave .

3. Safety Norm

Summary

- 1、 all safety switches and devices must be checked in advance every day before using the forklift and ensure these safety facilities are normal to work.
- 2、 Check to ensure all the warning labels and rated parameter plates are normal as attached on the vehicle.
- 3、 It doesn't allow to use the stacker under the circumstance that the stacker gets

something broken, or there is fault which affects the safety.

4、 There should be professionals who are charge in maintaining, repairing and fixing the forklift.

Forklift Operation

Forklift may lift and lower freely within a certain altitude scope. Specially manufactured is the forklift which is used for refrigeration house. Based on the design and manufacture of forklift, some working occasions are inappropriate as below:

- 1、 There is inflammable and explosive dust or gas in the air of work site.
- 2、 The forklift plays a role of a tow truck for another vehicle.
- 3、 The forklift is used to transport or elevate a person.

The responsibility of forklift operator

- 1、 The forklift operator cannot operate the forklift without training and recognition.
- 2、 Abide by this operating manual, as well as the local legal regulation of safety, and traffic rules.
- 3、 It is prohibitive to operate the forklift when the operator's hands and feet are oily.

Work Site

- 1、 the forklift is only able to be operated on even solid road such as concrete or pitch road. Do not operate on oily area, in case of slipping of travel wheels.
- 2、 Ensure the ground or floor has sufficient load capacity that can load the total amount of weight of forklift, namely the aggregate weight of the forklift and the goods plus the operator.
- 3、 Operating Guidance in the process of Travel:
 - (a) Avoiding sudden braking or turning at a fast travel speed.
 - (b) Keeps the goods at the bottom during travelling.
 - (c) During all the process of travelling on ramp, slow down the travel speed and keep the goods at the bottom, it is banned from direction turning as well as mast lifting and lowering.
 - (d) Slow down if the road is slippery, in case of idling or rollover of forklift.
 - (e) Except of the process of loading and off-loading goods, the goods forks should be lowered to as no more than 200 mm as the height from the ground during the process of travelling. don't lift and rotate goods at the same time.
- 4、 Someone is needed to direct you around if your sight is confined, ensure safety.
- 5、 Keep a certain safety distance from front vehicle, persons, and objects.
- 6、 Honk horn if excessive speed.
- 7、 Forklift is prohibited from transporting person.
- 8、 Ensure the elevator has sufficient load capacity for the whole weight of forklift, before entering into.
- 9、 Loading & off-loading of Goods
 - (a) Only allowed to lift the goods forks to operate during the process of off-loading

the goods or forking the goods, meanwhile keeping the distance from persons around the vehicle. It is banned from lifting and lowering or tilting goods forks during the process of travelling, meanwhile keep the height of goods forks as no more than 200 mm as the height from the ground.

(b) The transported goods keeps symmetric, compares the left side to the right; it is not allowed to transport the unstable and unsafe.

(c) Banned from touching the mast when lifting goods, in case of pinching hands.

(d) It is only allowed to load or off-load goods at the range of maximum lifting weight and load centre, moreover adjust the symmetric position of goods loaded on the goods forks, in light of the outer size of the goods. Refer to the load capacity chart in details.

(e) Be more discreet when loading or off-loading those which are higher and heavier; it must be equipped with load-backrest when loading or off-loading those goods that are gigantic.

10、 Attention for Vehicle Parking

(a) Lower the forks to the lowest after stable parking.

(b) Banned from parking on ramp

(c) Parking at an appointed place

(d) Banned from parking on the emergency exit

(e) Banned from parking at busy work place.

(f) Shut off power supply after forklift parking.

4、 Battery

Replacement of Battery

Only replace the battery by those that are of the same model and the same weight. (the weight of battery affects the performance of the stability & the braking of forklift .)

Notice !

Banned from modifying the weight and size, otherwise the centre gravity of vehicle body will be affected. The overweight and short-weight of battery will affect the stability & the braking of forklift, the weight has to be in accordance with the nameplate that is attached on forklift.

1、 the sequence of the taking out of the battery that is with low electric quantity:

(a) Pull out the plug of power supply

(b) Open the housing of forklift case

(c) Unplug the plug of battery out of the plug of vehicle body.

(d) Pull the battery pack out of the forklift by a proper battery hook.

2、 the sequence of the replacement of the battery:

(a) Use a lift hoist to hang up the battery that is of sufficient electric quantity to put in the battery case.

- (b) Plug the plug of battery into the plug of vehicle body.
- (c) Close the housing of battery case.

Charging

Banned from smoking and open fire when charging. May use an automatic charger to charge the battery.

Notice!

The electrolyte of battery contains dilute sulphuric acid that is corrosive, flush by water and soap as soon as it splashes onto human skin, please contact and see a doctor if it splashes into human eye. Must wear protective goggles and gloves when check the battery.

3、Charging Preparation

Must charge the battery within 24 hours after use.

- (a) Turn key switch to turn-off condition after parking, pull out the key.
- (b) Ensure the favourable ventilation above the battery, open the vent caps of battery.
- (c) Unplug the plug of power supply, plug the plug of charger into the plug of power supply of battery.
- (d) Switch on alternating current and start charging by the charger。

Notice !

Keep favourable ventilation when charging, especially in close zone. During the process of charging, battery produces hydrogen, oxygen that triggers explosion so long as mixing with open fire and electric sparks.

Cut off charging power supply before unplugging the plug of power supply.

4、Charging Period

During the process of charging, the following methods by which we can draw a conclusion whether the battery charged is sufficient to electric quantity.

- (a) The specific gravity of electrolyte of battery keeps stable in more than 2~3 hours.
- (b) The surface of battery electrolyte produces bubble, the colour of electrolyte has been become clear from milky white.

The above conditions indicate the electric capacity of battery has been sufficient by charging.

5、After the completion of battery charging

- (a) Power off alternating power supply, as well as charger.
- (b) Unplug the charger plug from the plug of battery.
- (c) Turn key switch to turn-off position, plug the power-supply plug of battery into the vehicle-body plug of battery.
- (d) Close the vent caps of battery.

The sufficient-electric-capacity battery comparison table between its temperature

and its specific gravity of electrolyte as below:

Temperature ° C	Specific Gravity g/cm ³
-15	1.31
0	1.30
+15	1.29
+30	1.28
+45	1.27

Add acid liquor or distilled water to adjust if inconformity to the specific gravity out of the table.

Upkeep of Storage Battery

- 1、 In order to keep the use life of storage battery, the battery should be charged fully before come into use, undercharged battery may not to be used.
- 2、 Storage battery avoids overcharge and over-discharge as much as possible, overcharge and over-discharge heavily affect the use life of storage battery.
3. Keep clean to the electrolyte solution's pore plug & vent lids, take them off or open them when charging, fit them on or close them when charging completion. Keep clean and dry to the surface, connecting wire and screws of storage battery. Use cotton yarn that is dipped in with acid liquor to wipe it off if sulfuric acid attached. Attention ! don't let alkaline liquor into the battery.
4. After the charging completion, must check the acid liquor's height of storage battery, in time make up for the distilled water and keep the acid liquor's height. Normally, banned to make up for adding dilute sulphuric acid.
5. It is a must to charge battery in time after using battery, no more than 24 hours to commonly place the battery without charging.
- 6、 Keep favorable ventilation when charging, banned from smoking.
- 7、 Storage battery must to be charged by the way of equalizing charge under the circumstances as follows.
 - (a) Normally-used storage battery (equalizing charge once three months)
 - (b) Unused storage battery of long-term laying aside
 - (c) There are "delayed batteries" arrayed in battery pack (delayed batteries means their voltage are lower than other batteries' during the process of charging and discharging, or those batteries that have been repaired, because of their faults. At this moment, equalizing charging only individually proceeds on delayed battery.
- 8、 Method of equalizing charging
 - (a) First, proceed on ordinary charging
 - (b) Stop charging for one hour at the fully charged status, then charge again for one hour by the charging of 0.25C₅
- 9、 When storage battery stops using, proceed on replenished charging once a month during placed period.
- 10、 Storage battery should avoid direct sunlight, no less than 2 meter close to heat source.

11、 Avoid any liquid and harmful material to contact, any metallic debris cannot be dropped into battery.

5. Troubleshooting

Serial	Faults	Reason	Solution
1	The forks cannot lift to the top	Hydraulic oil is insufficient	Fill with hydraulic oil
2	The forks cannot lift	Either no hydraulic oil, or the oil is impure	Either fill with hydraulic oil, or replace the oil.
3	The motor of pump station doesn't work	1. has not switched on emergency switch. 2. the voltage of battery is low. 3. the connector of power supply is loose. 4. the contactor of motor is broken.	1. switch on the emergency switch. 2. charge the battery. 3. fasten. 4. replace
4	The forks cannot lower	1.deformation of the big piston rod or oil cylinder body, due to deviated or overloads goods. 2.long-time parking of goods forks at the higher position, it results that the piston rod gets rusty by the exposure of the rod in the air and obstruct the move of the piston. 3.the relief valve of pump station cannot open, due to its worn or broken.	1. replace the piston rod or oil cylinder. 2. please lower the forks to the lowest after use, pay attention to lubricate the piston rod. 3. replace the relief valve of pump station
5	Oil leakage	1.oil seal is ageing or broken. 2. some parts are cracked	1. replace 2. replace
6	Goods forks slide downwards by themselves	1. the relief valve cannot close tightly, due to the impure hydraulic oil. 2. sealing piece is ageing or broken. 3. the relief valve is broken	1.replace 2.replace it by new one 3 replace it by new one
7	battery fails to be charged	1. battery is broken 2.the charging plug is loose	1. replace by new one 2. plug tightly

Attention: banned from arbitrary repairing without authorization and training.

6、 Upkeep & Maintenance

Regular upkeep once per 500-hour operation of forklift; the efficiency, use life and safety of forklift reply on routine upkeep. The replaced parts should be supplied by the original manufacturer KING-Lift to ensure the quality. Recommend the end users to contact the agent of the product or the persons who are in charge of after-service of King-lift company, in order to ensure your forklift to perform safer and more economical.

Safety Rule of Maintenance Work

The maintenance is only worked on by those who have systematically studied the maintenance.

1. Keep the maintaining site clean and sanitary

2. Don't bring loose item and valuables with your body during maintenance

Attention !

During the process of maintaining the electrical system of forklift, please take off wrist watch, earrings and metal ornaments, in case that it could be short-circuited or burnt when metal contacts the electrical elements.

3、 First unplug the plug of power supply, then shut off power supply before the maintenance of forklift.

4、 Must turn key-switch to turn-off and press down emergency switch before opening the rear cover.

5、 Release the system pressure as lowering the forks before checking the hydraulic system.

6、 Don't use hand to contact directly before checking the oil leakage of vehicle body, in case of scalding.

7、 the temperature of the oil inside transmission gear or hydraulic system may be high, must cool down the forklift before replacing the gear oil or hydraulic oil, in case that the oil temperature is so high that the oil burns.

8、 Fill the hydraulic system with new hydraulic oil, 46# Hydraulic oil is advisable .

Attention !

If the hydraulic oil is not clean, that could affect the precise hydraulic elements and make the performance of hydraulic system decreased . If use the hydraulic oil of different brand, that harms hydraulic elements, also affects the performance of hydraulic elements, therefore, please pay attention to using the oil of identical brand during adding or replacing the hydraulic oil.

9、 Please abide by some relevant legal rules, protect environment, store and discharge the oil material in accordance with some stipulations,it is prohibited from discharging it into sewer pipes.

10、 Please cut off power supply if vehicle body needs welding, in case that the electric current goes into the storage battery.

11、 Every and each parts of human body cannot enter under the mast or the forks without reliable bracket.

Notice !

Forklift could be rolled over to hurt persons if inappropriate holding up; it is banned from working under the vehicle if there is no lifting equipment or no propping protection of bracket.

Some maintenance work could be accomplished by users.

Daily maintenance & safety check

1. It is duty for a forklift operator to keep routine maintenance and check.
- 2、 It affects the safety and reliability of forklift without routine maintenance, that could result in accidents occurred.
- 3、 Immediately stop using the forklift, in addition, engaging in fixing, as soon as detecting its problem or finding out its faults.
- 4、 In order to keep the vehicle in good using status, it is necessary to check and maintain the vehicle every day, the crucial checking is as follows:

Serial	Component checked	Checking content
1	Operating control	Check if it is normal to work
2	Belly Switch	Check if it is normal to work
3	Horn	Check if it is normal to work
4	Steering	Check if it is normal to work
5	Hydraulic device	Check if it is normal to work
6	Coulombmeter	Check if it is normal to work
7	Hydraulic system	Check the oil level and whether there is oil leakage or not
8	Drive Device	Check if there is abnormal noise or oil leakage
9	Clutch, Brake	Check if it works, or with poor contact
10	Transmission	Check if they are normal to work
11	Vehicle wheels	Check if they are damaged after wiping off oil dirt & metal chips
12	Chassis frame	Check if they are damaged after wiping off oil dirt
13	Goods forks	Check if they are deformed or cracked
14	Hydraulic cylinder	Check if it is damaged or oil leakage

Clean up Forklift

Proceed on regular cleaning per week, it is crucial to ensure its reliability. Please unplug the socket of power supply before cleaning, in case of short circuit that will damage the electrical system.

Clean away the exterior of vehicle

1. Clear away the attachment attached on the vehicle per day to keep its flexible rotation.
- 2、 Must blow off the dust on the motor by air-compressor when cleaning up the

electrical elements, it is by no means to use damp cloth to wipe off the dust on the electrical wiring.

3、 Must replenish grease oil on some related parts after the completion of cleaning up.

Attention !

Electrical elements cannot be flushed by high-pressure water, to avoid short circuit by unable to destroy the electrical elements on electric board.

7. Electrical Schematic diagram

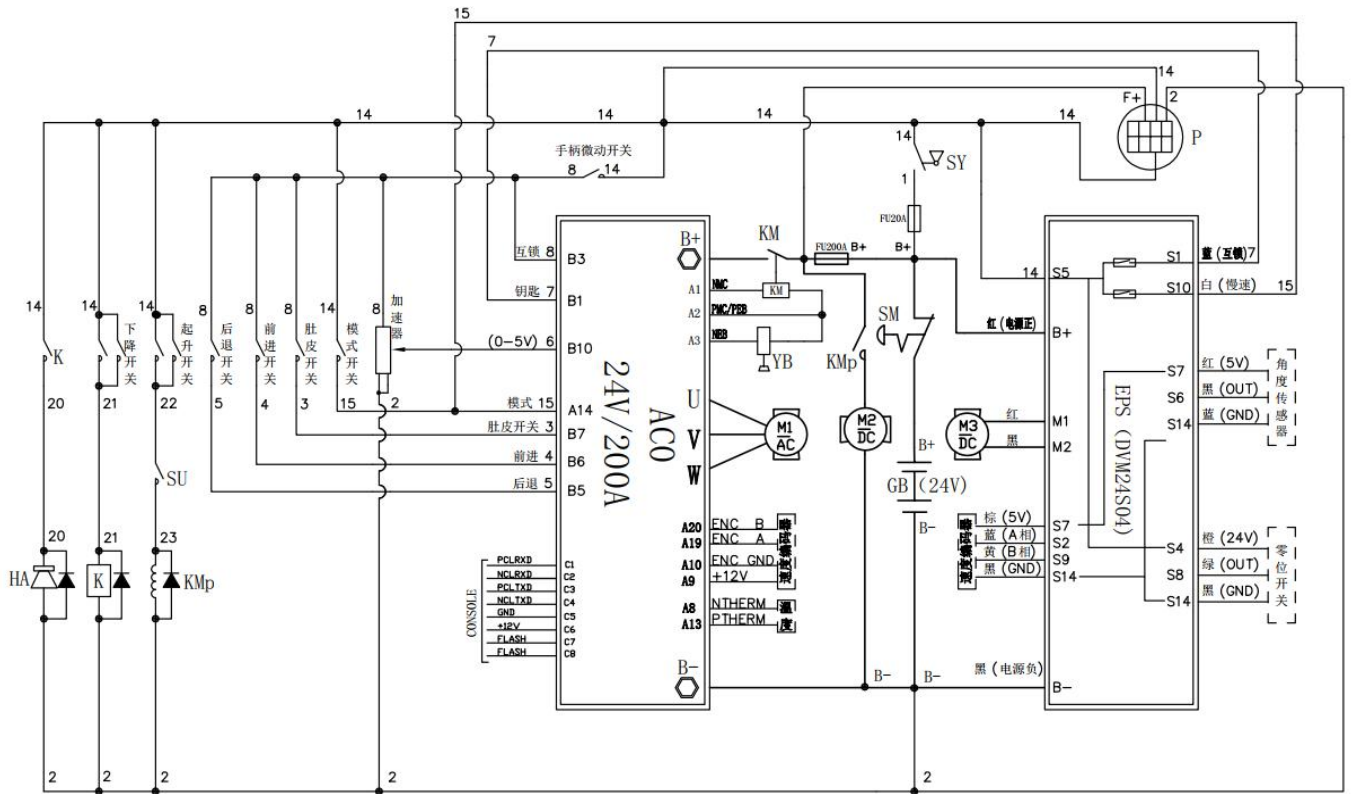

(KLA/KLA-E)

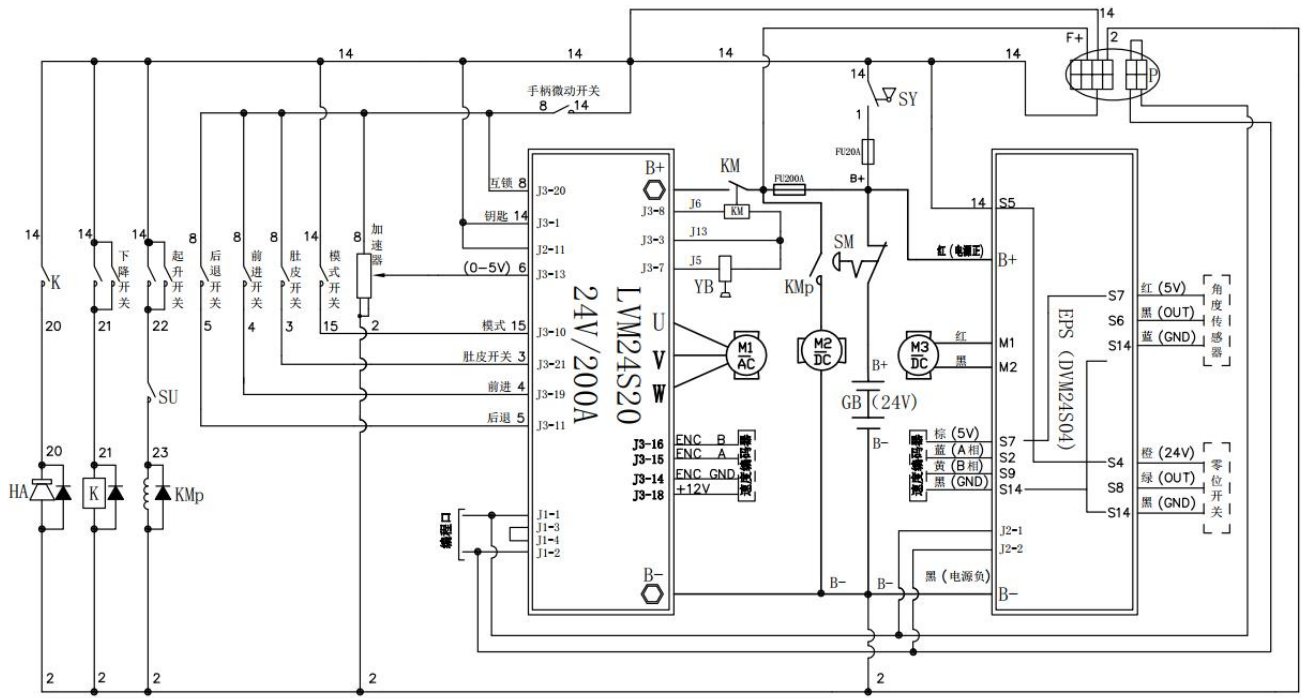

(KLA-H)